

HYDRAULIC CYLINDER "SC-200/140-1965-L112"

Production Report For Mechanical Maintenance

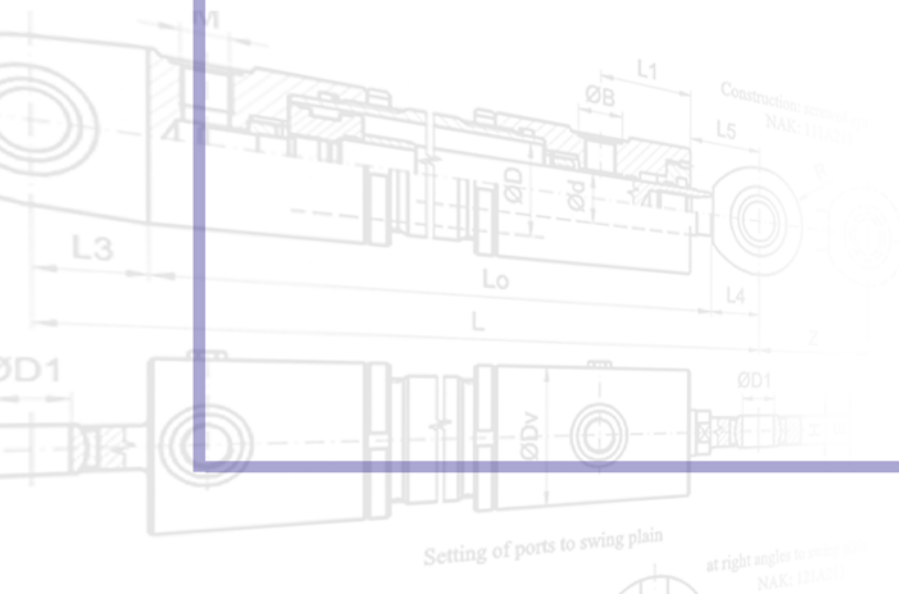

Job.P018



Hydraulic Cylinder “SC-200/140-1965-L112”

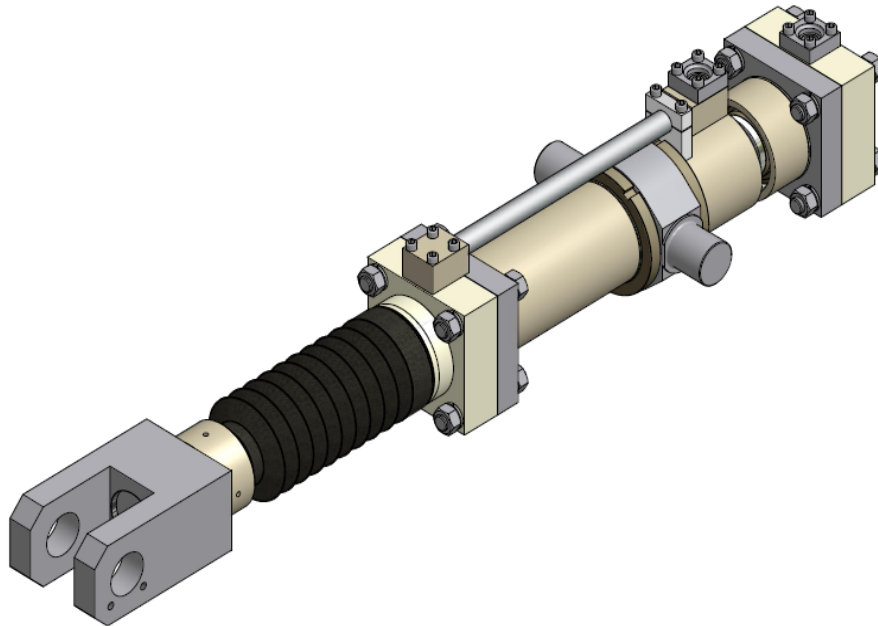

Hydraulic Cylinder 200x140x1965

Bore size: Ø200 mm.

Rod size: Ø140 mm.

Stroke: 1965 mm.

Working Pressure: 140 Bar

SR No. : 62/038

Job No. : P018

SC-200/140-1965-L112

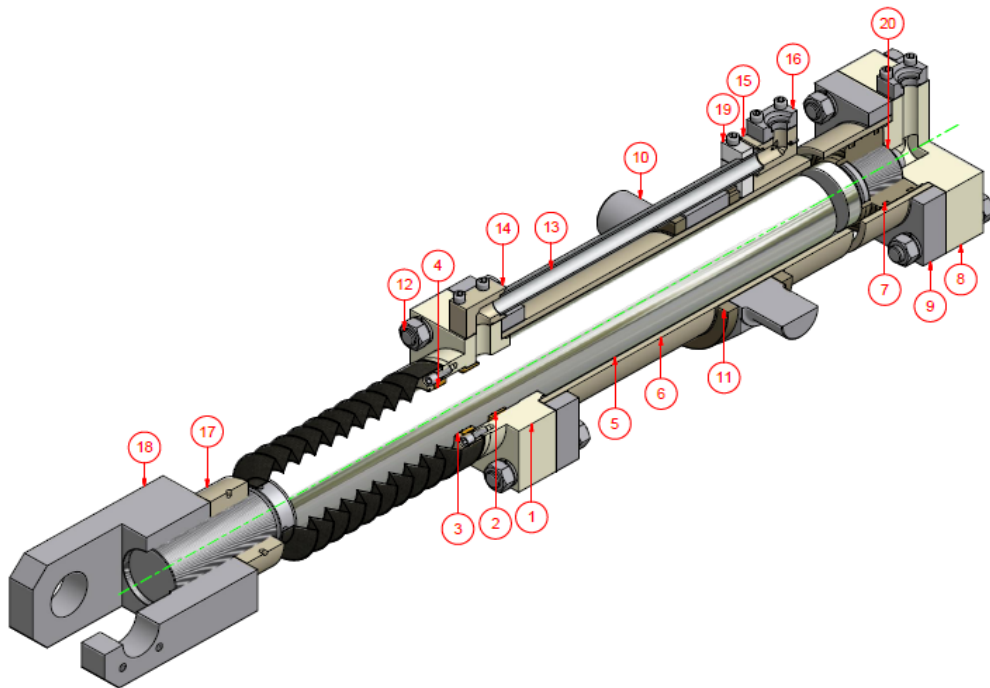

Part List SC-200/140-1965-L112

ITEM	P/N	QTY	PART NAME
1	SP-L112-01-01	1	HEAD CYLINDER
2	SP-L112-01-02	1	GUIDE BUSH
3	SP-L112-01-03	1	FRONT COVER
4	SP-L112-01-04	1	REAR GUIDE BUSH
5	SP-L112-02-01	1	ROD
6	SP-L112-03-01	1	TUBE CYLINDER
7	SP-L112-04-01	1	PISTON
8	SP-L112-05-01	1	END CYLINDER
9	SP-L112-06-01	2	FLANGE TUBE
10	SP-L112-06-02	1	TRUNNION
11	SP-L112-06-03	2	LOCKING RING
12	SP-L112-06-04	8	TIE ROD
13	SP-L112-06-05	1	PIPE
14	SP-L112-06-06	1	FLANGE LSA-40
15	SP-L112-06-07	1	FLANGE LSB-40
16	SP-L112-06-08	2	FLANGE SSA-40
17	SP-L112-06-09	1	NUT LOCK
18	SP-L112-06-10	1	MOUNTING ROD
19	SP-L112-06-11	1	CLAMP PIPE
20	SP-7027-05-02	1	CUSHION KID CAP



Siam Hydraulic Co.,Ltd.

888 Lasalle Road, Bangna Tai, Bangna, Bangkok 10260

Tel./Fax. 02-399 0939 E-mail : Sale1@siamhyd.com, website : www.siamhyd.com

รูปชิ้นส่วนที่ผลิต (Job.P018)

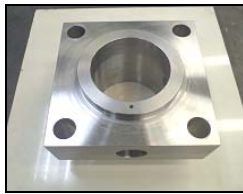

Head Cylinder



Guide Bush



Front Cover



Rod



Tube Cylinder



Piston

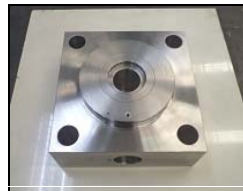

End Cylinder



Flange Tube



Trunnion



Locking Ring



Tie Rod



Pipe



Flange LSA-40



Flange LSB-40



Nut lock



Flange SSA-40



Mounting Rod



Clamp Pipe



Rear Guide Bush



Bellow



Screw Set



Cushion Valve



Cushion Kid Cap



Seal Kit

ภาพการประกอบและทดสอบ Hydraulic Test (Job.P018)



HYDRAULIC TEST REPORT

CUSTOMER NAME:

PROJECT NO.: SC-200/140-1965-L112

REF. P/O NO. : -

QUOTATION NO. :-

QUALITY: 1 Set

TYPE: 200x140x1965

DATE: -

DATE: -

DELIVERY DATE: -

TEST PRESSURE

WORKING PRESSURE: 140 Bar

MAXIMUM TEST: 250 Bar

TESTING TIME: 30 Minute

TEST BY
SERVICES TECHNICIAN

INSPECTION BY
ENGINEER



Siam Hydraulic Co.,Ltd.

888 Lasalle Road, Bangna Tai, Bangna, Bangkok 10260

Tel./Fax. 02-399 0939 E-mail : Sale1@siamhyd.com, website : www.siamhyd.com

SIAM HYD

Siam Hydraulic Co.,Ltd

High quality cylinders for heavy duty application