

AIR CYLINDER “SC-200/050-380-L018”

Production Report For Mechanical Maintenance

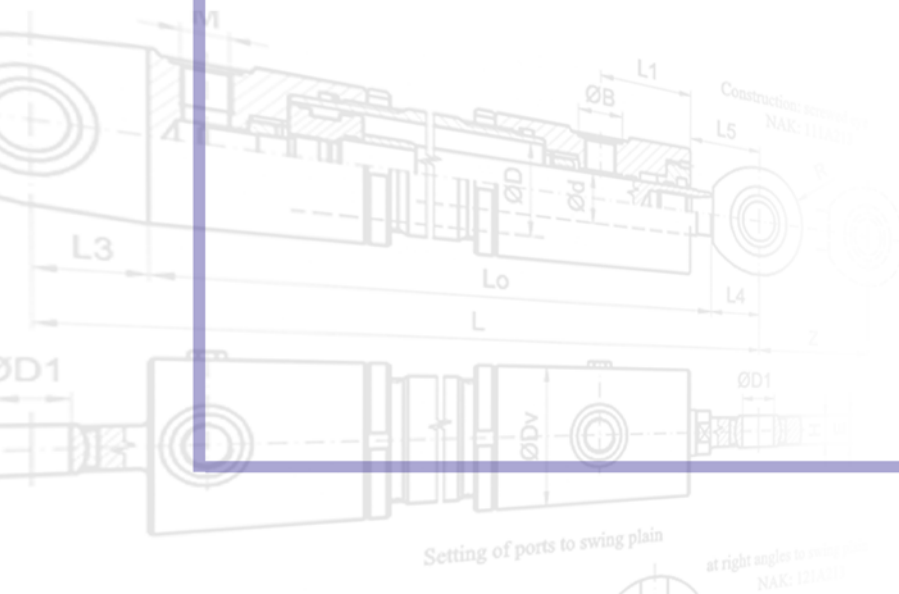

Job.L018

www.siamhyd.com

Air Cylinder “SC-200/050-380-L018”



Air Cylinder 200x50x380

Bore size: $\text{Ø}200$ mm.

Rod size: $\text{Ø}50$ mm.

Stroke: 380 mm.

Working Pressure: 10 Bar

SR No. : 59/026

Job No. : L018



Siam Hydraulic Co.,Ltd.

888 Lasalle Road, Bangna Tai, Bangna, Bangkok 10260

Tel./Fax. 02-399 0939 E-mail : Sale1@siamhyd.com, website : www.siamhyd.com

SC-200/050-380-L018

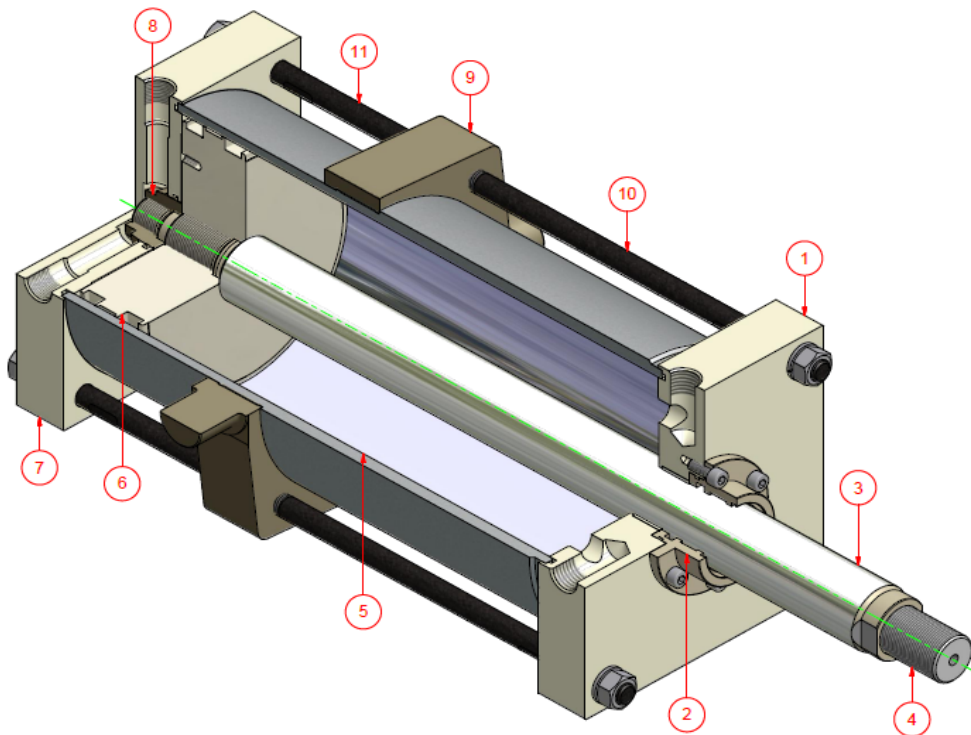

Part List SC-200/050-380-L018

ITEM	P/N	QTY	PART NAME
1	SP-L018-01-01	1	HEAD CYLINDER
2	SP-L018-01-02	1	GLAND
3	SP-L018-02-01	1	ROD
4	SP-L018-02-02	1	ROD INSERT
5	SP-L018-03-01	1	TUBE CYLINDER
6	SP-L018-04-01	1	PISTON
7	SP-L018-05-01	1	END CYLINDER
8	SP-L018-05-02	1	END CUSHION SLEEVE
9	SP-L018-06-01	1	TRUNNION
10	SP-L018-06-02	4	TIE ROD HEAD
11	SP-L018-06-03	4	TIE ROD END

รูปชิ้นส่วนที่ผลิต (Job.L018)



Head Cylinder



Gland



Rod



Rod Insert



Tube Cylinder

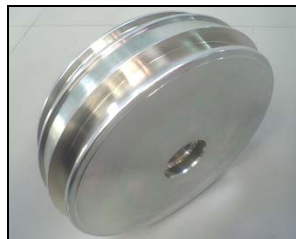

Piston



End Cylinder



End Cushion Sleeve



Trunnion



Tie Rod Head



Tie Rod End



Cushion Valve



Screw & Nut Set



Seal Kit

ภาพการผลิต,ประกอบและทดสอบแรงดัน (Job.L018)



Siam Hydraulic Co.,Ltd.

888 Lasalle Road, Bangna Tai, Bangna, Bangkok 10260

Tel./Fax. 02-399 0939 E-mail : Sale1@siamhyd.com, website : www.siamhyd.com



AIR TEST REPORT

CUSTOMER NAME:

PROJECT NO.: SC-200/050-380-L018

TYPE: 200x50x380

REF. P/O NO. : -

DATE: -

QUOTATION NO. :-

DATE: -

QUALITY: 1 Set

DELIVERY DATE: -

TEST PRESSURE

WORKING PRESSURE: 10 Bar

MAXIMUM TEST: 15 Bar

TESTING TIME: 30 Minute

TEST BY

SERVICES TECHNICIAN

INSPECTION BY

ENGINEER



Siam Hydraulic Co.,Ltd.

888 Lasalle Road, Bangna Tai, Bangna, Bangkok 10260

Tel./Fax. 02-399 0939 E-mail : Sale1@siamhyd.com, website : www.siamhyd.com

SIAM HYD

Siam Hydraulic Co.,Ltd

High quality cylinders for heavy duty application