

HYDRAULIC CYLINDER “SC-125/070-250-L028”

Production Report For Mechanical Maintenance

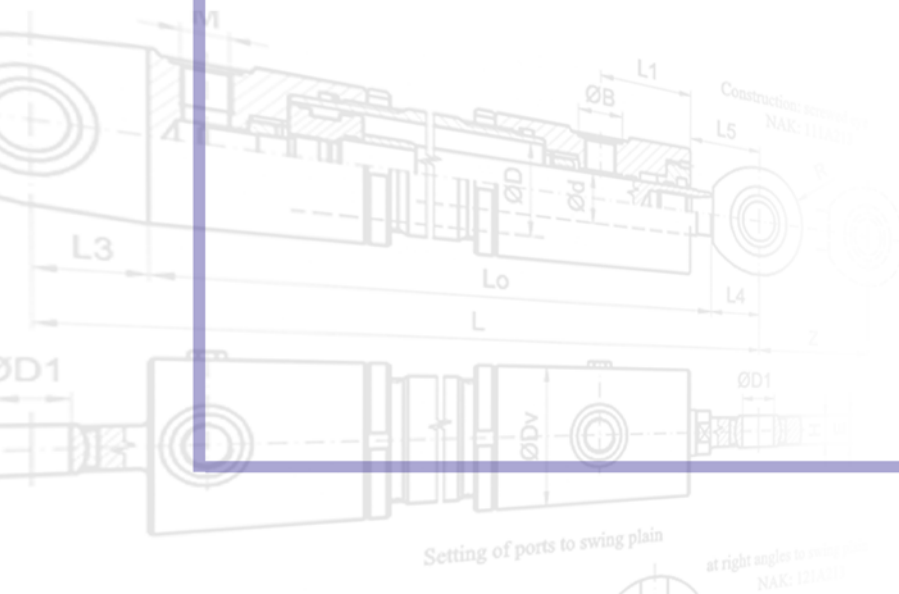

Job.N092

Hydraulic Cylinder “SC-125/070-250-L028”

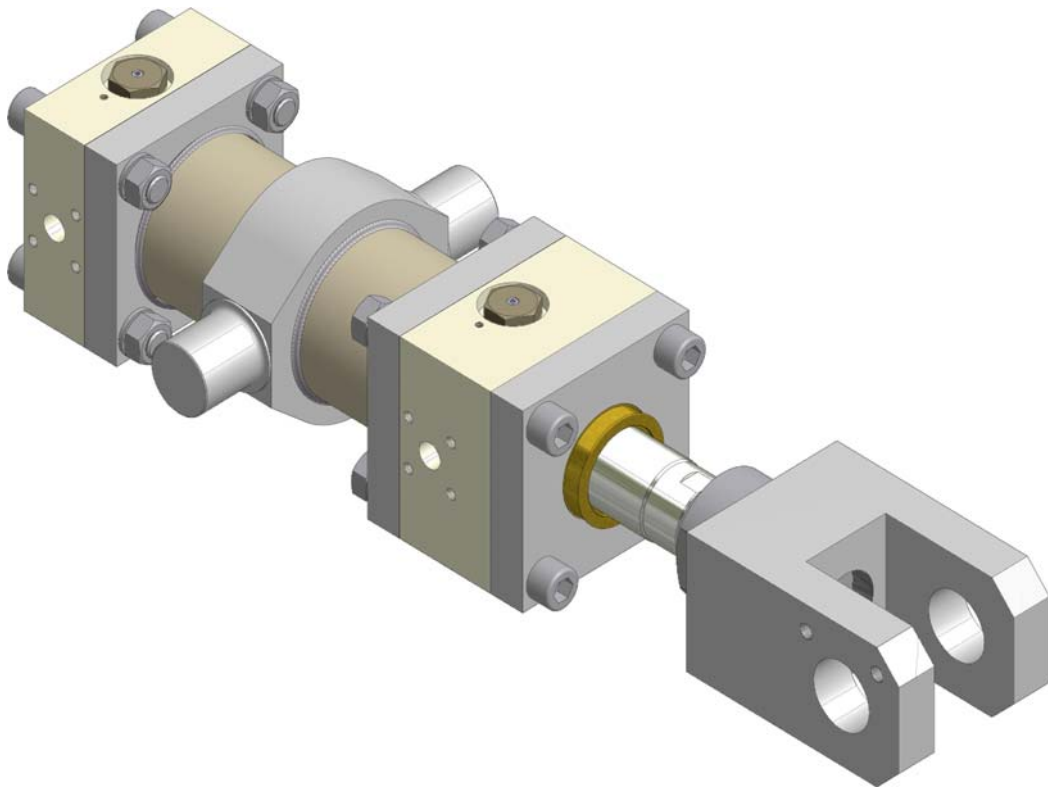

Hydraulic Cylinder 125x070x250

Bore size: $\text{Ø}125$ mm.

Rod size: $\text{Ø}070$ mm.

Stroke: 250 mm.

Working Pressure: 140 Bar

SR No. : 61/092

Job No. : N092 (No.1,2)



Siam Hydraulic Co.,Ltd.

888 Lasalle Road, Bangna Tai, Bangna, Bangkok 10260

Tel./Fax. 02-399 0939 E-mail : Sale1@siamhyd.com, website : www.siamhyd.com

SC-125/070-250-L028

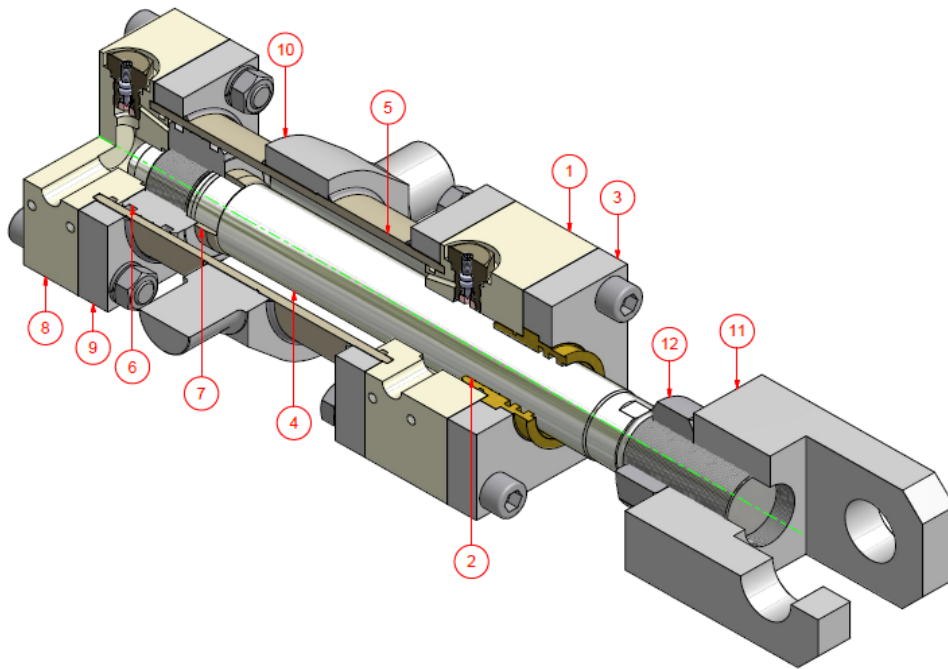

Part List SC-125/070-250-L028

ITEM	P/N	QTY	PART NAME
1	SP-L028-01-01	1	HEAD CYLINDER
2	SP-L028-01-02	1	GLAND
3	SP-L028-01-03	1	FRONT COVER
4	SP-L028-02-01	1	ROD
5	SP-L028-03-01	1	TUBE CYLINDER
6	SP-L028-04-01	1	PISTON
7	SP-L028-04-02	1	CUSHION SLEEVE
8	SP-L028-05-01	1	END CYLINDER
9	SP-L028-06-01	2	FLANGE TUBE
10	SP-L028-06-02	1	TRUNNION
11	SP-L028-06-03	1	MOUNTING ROD
12	SP-L028-06-04	4	NUT LOCK

รูปชิ้นส่วนที่ผลิต (Job.N092)

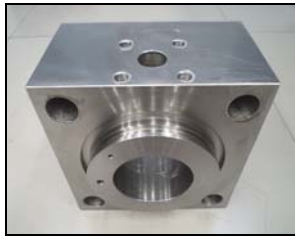

Head Cylinder



Gland



Front Cover



Rod

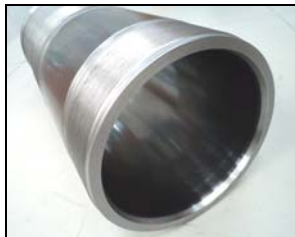

Tube Cylinder



Piston



Cushion Sleeve



End Cylinder



Flange Tube



Trunnion



Mounting Rod



Nut Lock



Cushion Valve



Screw Set



Bellow



Seal Kit

ภาพการผลิต,ประกอบและทดสอบ Hydraulic Test (Job.N092)

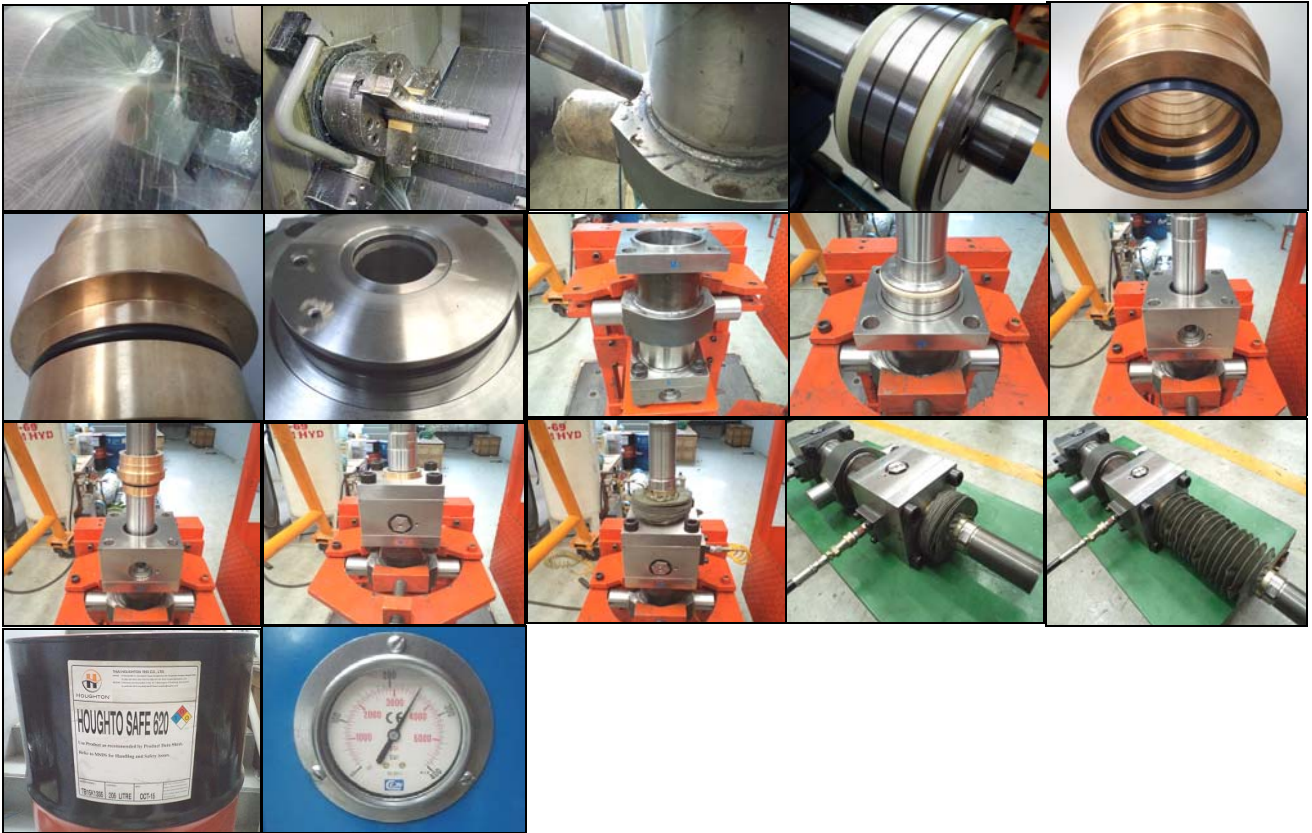

HYDRAULIC TEST REPORT

CUSTOMER NAME:

PROJECT NO.: SC-125/070-250-L028

REF. P/O NO. : -

QUOTATION NO. : -

QUALITY: 2 Set

TYPE: 125x070x250

DATE: -

DATE: -

DELIVERY DATE: -

TEST PRESSURE

WORKING PRESSURE: 140 Bar

MAXIMUM TEST: 250 Bar

TESTING TIME: 30 Minute

TEST BY _____
SERVICES TECHNICIAN

INSPECTION BY _____
ENGINEER



Siam Hydraulic Co.,Ltd.

888 Lasalle Road, Bangna Tai, Bangna, Bangkok 10260

Tel./Fax. 02-399 0939 E-mail : Sale1@siamhyd.com, website : www.siamhyd.com

SIAM HYD

Siam Hydraulic Co.,Ltd

High quality cylinders for heavy duty application