

HYDRAULIC CYLINDER “SC-110/080-150-M035”

Production Report For Mechanical Maintenance

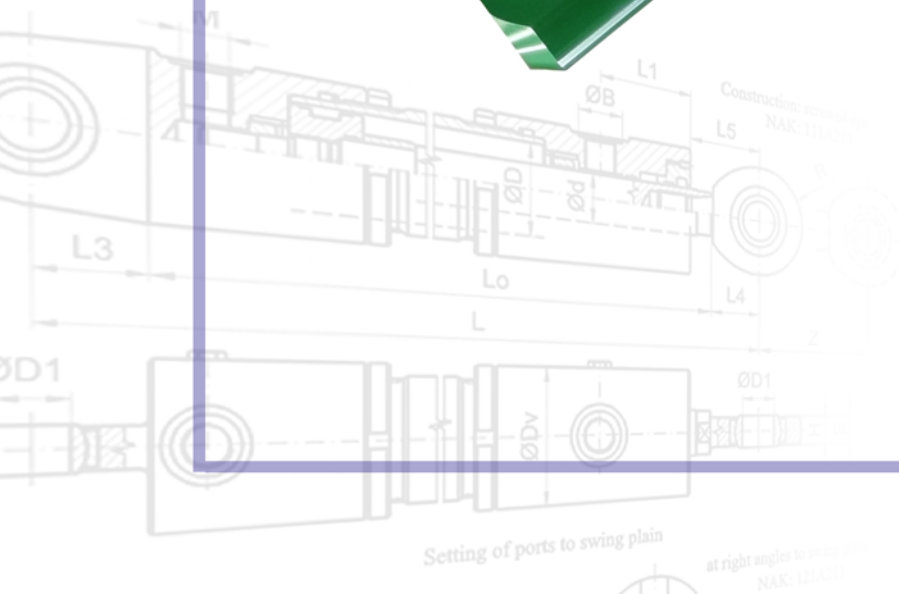

Job.P062

Hydraulic Cylinder “SC-110/080-150-M035”

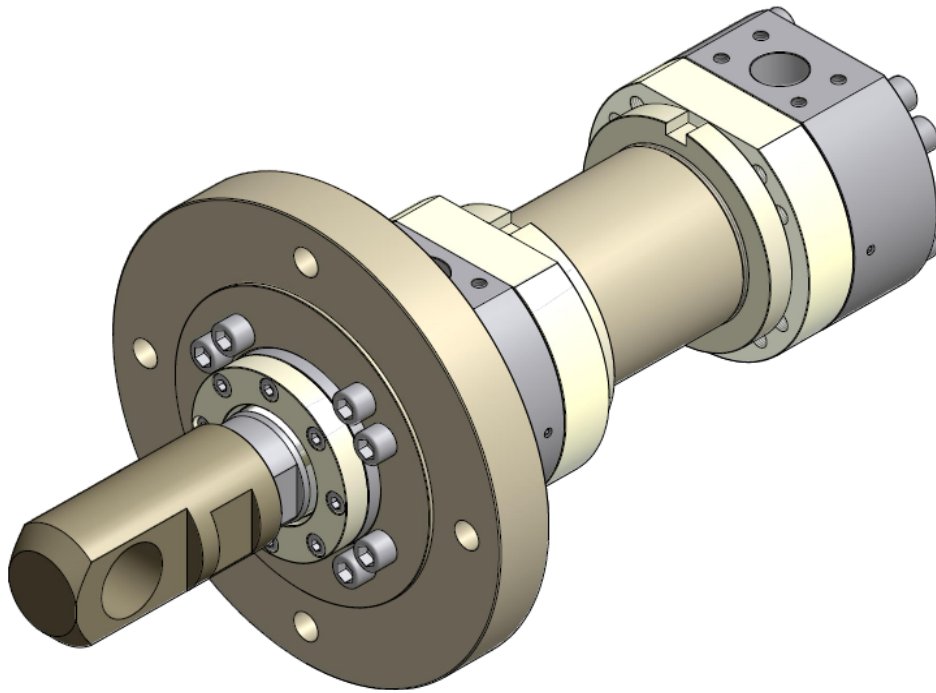

Hydraulic Cylinder 110x80x150

Bore size: Ø110 mm.

Rod size: Ø80 mm.

Stroke: 150 mm.

Working Pressure: 140 Bar

SR No. : SR62/068

Job No. : P062

SC-110/080-150-M035

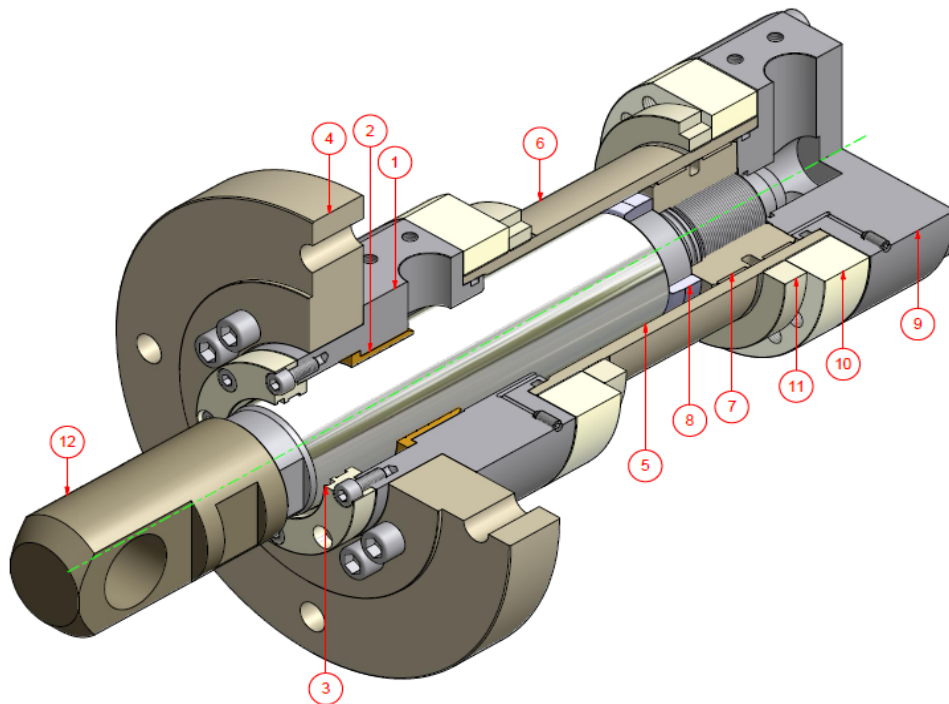

Part List SC-110/080-150-M035

ITEM	P/N	QTY	PART NAME
1	SP-M035-01-01	1	HEAD CYLINDER
2	SP-M035-01-02	1	GUIDE BUSH
3	SP-M035-01-03	1	FRONT COVER
4	SP-M035-01-04	1	FLANGE HEAD
5	SP-M035-02-01	1	ROD
6	SP-M035-03-01	1	TUBE CYLINDER
7	SP-M035-04-01	1	PISTON
8	SP-M035-04-02	1	CUSHION SLEEVE
9	SP-M035-05-01	1	END CYLINDER
10	SP-M035-06-01	2	FLANGE TUBE
11	SP-M035-06-02	2	LOCKING RING
12	SP-M035-06-03	1	MOUNTING ROD

รูปชิ้นส่วนที่ผลิต (Job.P062)



Head Cylinder



Guide Bush



Front Cover



Flange Head



Rod



Tube Cylinder



Piston



Cushion Sleeve

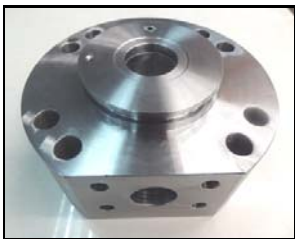

End Cylinder



Flange Tube



Locking Ring



Mounting Rod



Cushion Valve



Screw Set



Air Vent



Seal Kit

ภาพการประกอบ และ ทดสอบ Hydraulic Test (Job.P062)



HYDRAULIC TEST REPORT

CUSTOMER NAME:

PROJECT NO.: SC-110/080-150-M035

REF. P/O NO. : -

QUOTATION NO. :-

QUALITY: 1 Set

TYPE: 110x80x150

DATE: -

DATE: -

DELIVERY DATE: -

TEST PRESSURE

WORKING PRESSURE: 140 Bar

MAXIMUM TEST: 250 Bar

TESTING TIME: 30 Minute

TEST BY
SERVICES TECHNICIAN

INSPECTION BY
ENGINEER



Siam Hydraulic Co.,Ltd.

888 Lasalle Road, Bangna Tai, Bangna, Bangkok 10260

Tel./Fax. 02-399 0939 E-mail : Sale1@siamhyd.com, website : www.siamhyd.com

SIAM HYD

Siam Hydraulic Co.,Ltd

High quality cylinders for heavy duty application