

HYDRAULIC CYLINDER

“SC-100/070-420-L026”

Production Report For Mechanical Maintenance

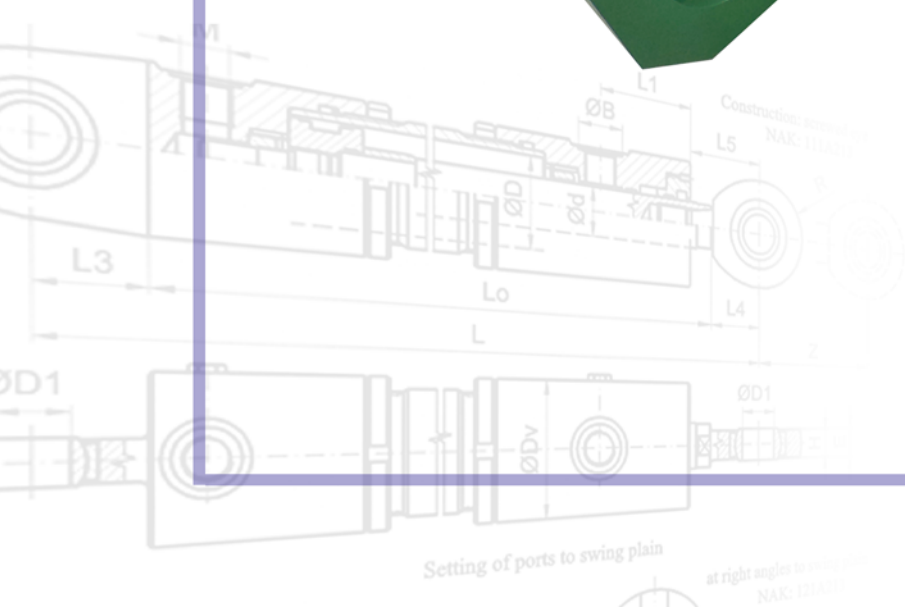

Job.N001

Hydraulic Cylinder “SC-100/070-420-L026”

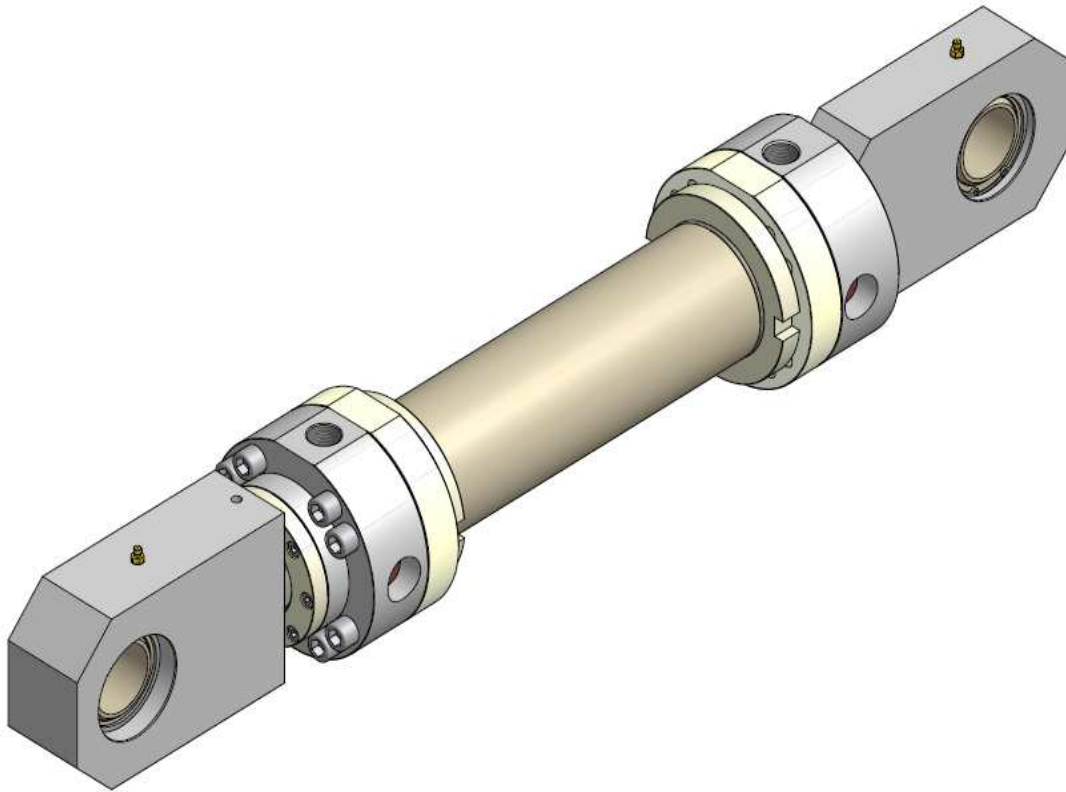

Hydraulic Cylinder 100x070x420

Bore size: $\text{Ø}100$ mm.

Rod size: $\text{Ø}70$ mm.

Stroke: 420 mm.

Working Pressure: 140 Bar

SR No. : 61/002

Job No. : N001



Siam Hydraulic Co.,Ltd.

888 Lasalle Road, Bangna Tai, Bangna, Bangkok 10260

Tel./Fax. 02-399 0939 E-mail : Sale1@siamhyd.com, website : www.siamhyd.com

SC-100/070-420-L026

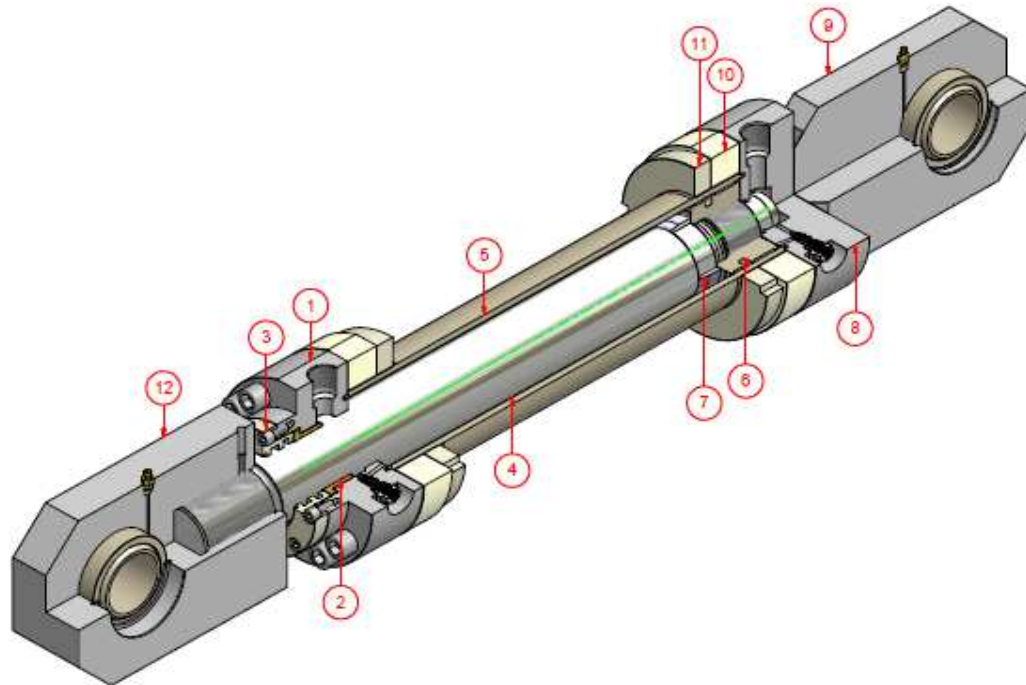

Part List SC-100/070-420-L026

ITEM	P/N	QTY	PART NAME
1	SP-L026-01-01	1	HEAD CYLINDER
2	SP-L026-01-02	1	GUIDE BUSH
3	SP-L026-01-03	1	FRONT COVER
4	SP-L026-02-01	1	ROD
5	SP-L026-03-01	1	TUBE CYLINDER
6	SP-L026-04-01	1	PISTON
7	SP-L026-04-02	1	CUSHION SLEEVE
8	SP-L026-05-01	1	END CYLINDER
9	SP-L026-05-02	1	END MOUNTING
10	SP-L026-06-01	2	FLANGE LOCK
11	SP-L026-06-02	2	LOCKING RING
12	SP-L026-06-03	1	MOUNTING ROD

รูปชิ้นส่วนที่ผลิต (Job.N001)



Head Cylinder



Guide Bush



Front Cover



Rod



Tube Cylinder



Piston



Cushion Sleeve



End Cylinder



End Mounting



Flange lock



Locking Ring



Mounting Rod



Bearing



Cushion Valve



Screw Set



Seal Kit

ภาพการผลิต , ประกอบ และ ทดสอบ Hydraulic Test (Job.N001)



HYDRAULIC TEST REPORT

CUSTOMER NAME:

PROJECT NO.: SC-100/070-420-L026

REF. P/O NO. : -

QUOTATION NO. :-

QUALITY: 1 Set

TYPE: 100x70x420

DATE: -

DATE: -

DELIVERY DATE: -

TEST PRESSURE

WORKING PRESSURE: 140 Bar

MAXIMUM TEST: 250 Bar

TESTING TIME: 30 Minute

TEST BY _____
SERVICES TECHNICIAN

INSPECTION BY _____
ENGINEER

SIAM HYD

Siam Hydraulic Co.,Ltd

High quality cylinders for heavy duty application