

HYDRAULIC CYLINDER “SC-100/063-125/290-N097”

Production Report For Mechanical Maintenance



Job.N097

www.siamhyd.com

Hydraulic Cylinder “SC-100/063-125-290-N097”

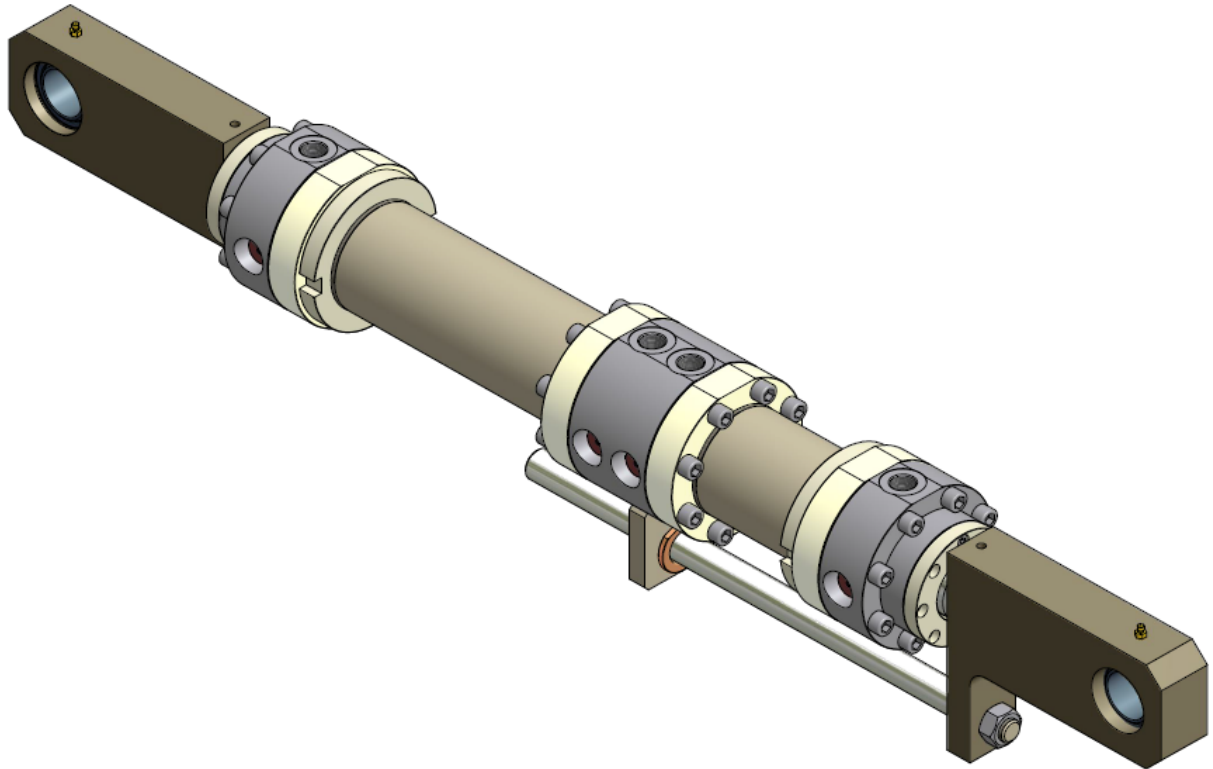

Hydraulic Cylinder 100x063x125/290

Bore size: $\text{Ø}100$ mm.

Rod size: $\text{Ø}63$ mm.

Stroke: 125/290 mm.

Working Pressure: 140 Bar

SR No. : 61/102

Job No. : N097 (No.1-3)

SC-100/063-125/290-N097

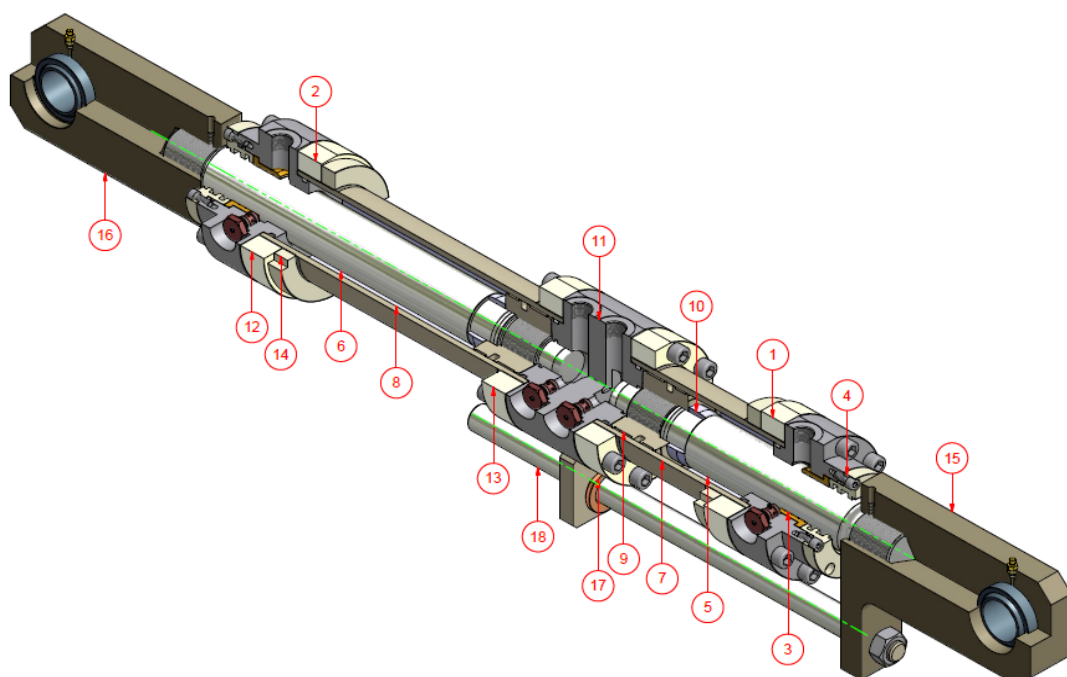

Part List SC-100/063-125/290-N097

ITEM	P/N	QTY	PART NAME
1	SP-N097-01-01	1	HEAD CYLINDER STEP 125
2	SP-N097-01-02	1	HEAD CYLINDER STEP 290
3	SP-N097-01-03	2	GUIDE BUSH
4	SP-N097-01-04	2	FRONT COVER
5	SP-N097-02-01	1	ROD STEP 125
6	SP-N097-02-02	1	ROD STEP 290
7	SP-N097-03-01	1	TUBE CYLINDER STEP 125
8	SP-N097-03-02	1	TUBE CYLINDER STEP 290
9	SP-N097-04-01	2	PISTON
10	SP-N097-04-02	2	CUSHION SIEEVE
11	SP-N097-05-01	1 Set	END SET
12	SP-N097-06-01	2	FLANGE HEAD
13	SP-N097-06-02	2	FLANGE END
14	SP-N097-06-03	2	LOCKING RING
15	SP-N097-06-04	1	MOUNTING ROD STEP 125
16	SP-N097-06-05	1	MOUNTING ROD STEP 290
17	SP-N097-06-06	1 Set	BUSHING SET
18	SP-N097-06-07	1	GUIDE ROD

รูปชิ้นส่วนที่ผลิต (Job.N097)



Head Cylinder Step 125



Head Cylinder Step 290



Guide Bush



Front Cover



Rod Step 125



Rod Step 290



Tube Cylinder Step 125



Tube Cylinder Step 290



Piston



Cushion Sleeve



End Set



Flange Head



Flange End



Locking Ring



Mounting Step 125



Mounting Step 290



Bushing Set



Guide Rod



Cushion Valve



Seal Kit

ภาพการผลิต, ประกอบและทดสอบ Hydraulic Test (Job.N097)



HYDRAULIC TEST REPORT

CUSTOMER NAME:

PROJECT NO.: SC-100/063-125/290-N097

REF. P/O NO. : -

QUOTATION NO. :-

QUALITY: 3 Set

TYPE: 100x63x125/290

DATE: -

DATE: -

DELIVERY DATE: -

TEST PRESSURE

WORKING PRESSURE: 140 Bar

MAXIMUM TEST: 250 Bar

TESTING TIME: 30 Minute

TEST BY
SERVICES TECHNICIAN

INSPECTION BY
ENGINEER

SIAM HYD

Siam Hydraulic Co.,Ltd

High quality cylinders for heavy duty application