

HYDRAULIC CYLINDER

“SC-100/056-890-L091”

Production Report For Mechanical Maintenance

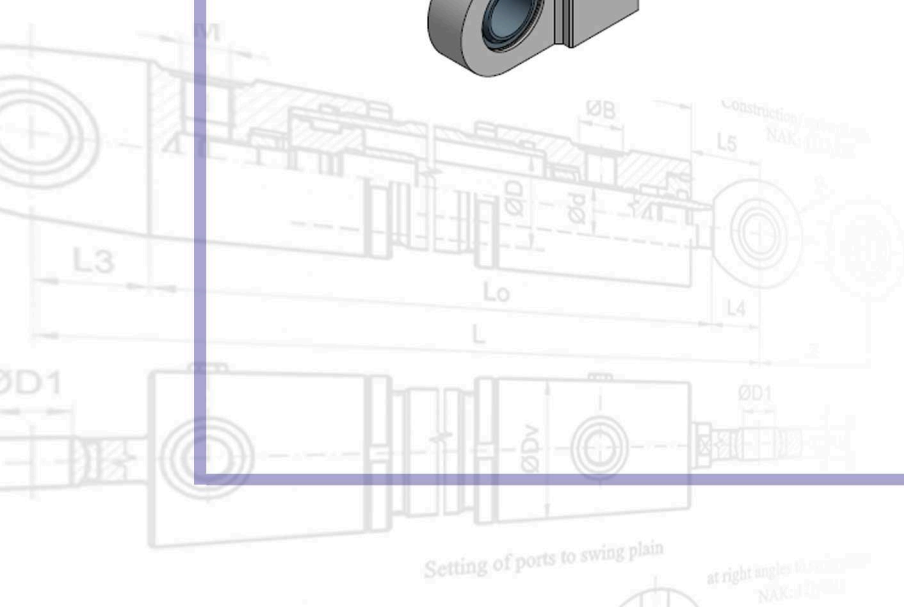
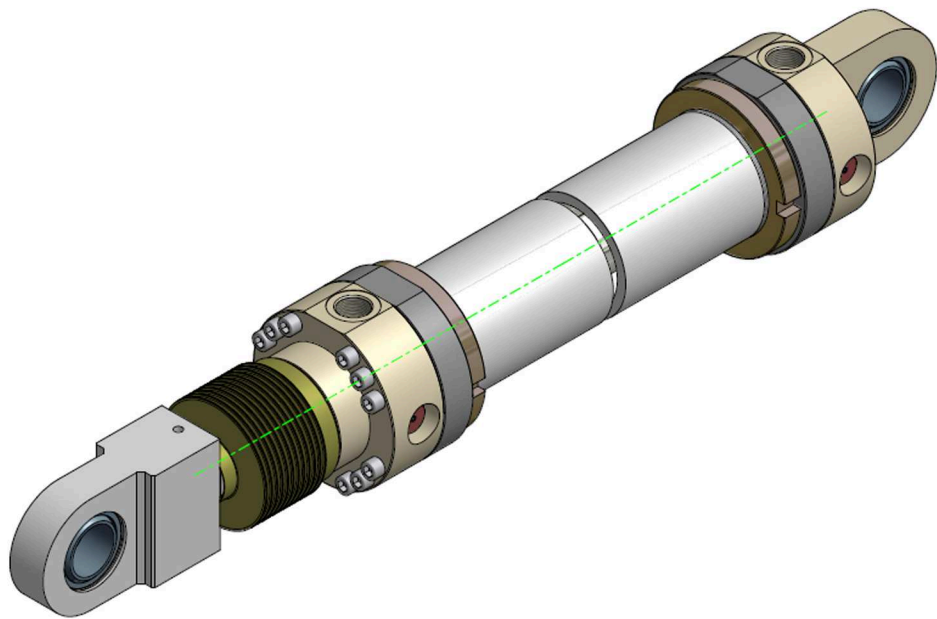

Job.N028

Hydraulic Cylinder “SC-100/056-890-L091”

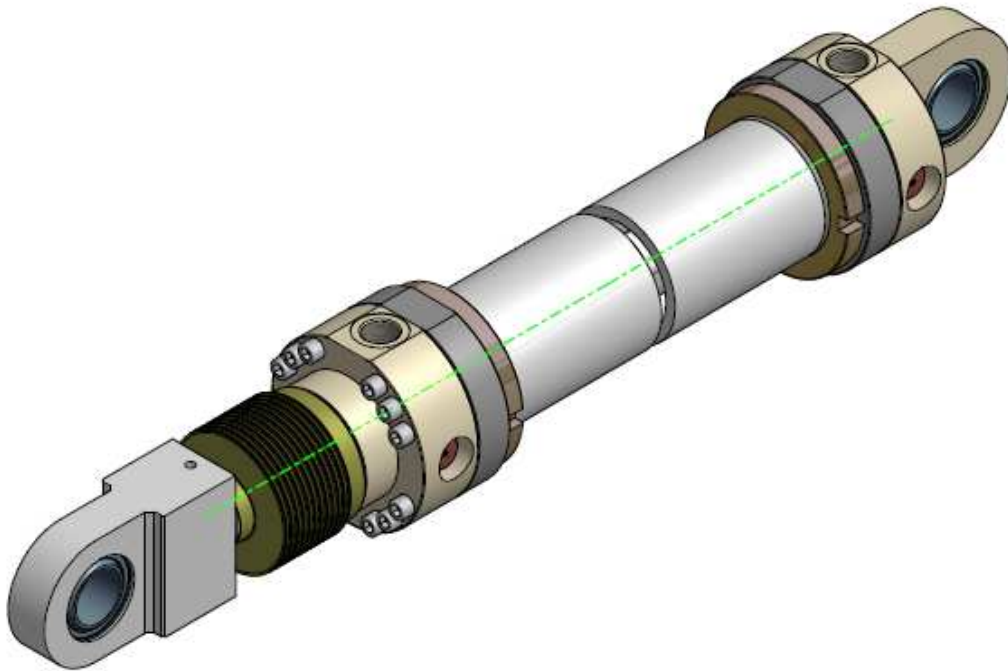

Hydraulic Cylinder 100x056x890

Bore size: $\text{Ø}100$ mm.

Rod size: $\text{Ø}56$ mm.

Stroke: 890 mm.

Working Pressure: 140 Bar

SR No. : 61/029

Job No. : N028



Siam Hydraulic Co.,Ltd.

888 Lasalle Road, Bangna Tai, Bangna, Bangkok 10260

Tel./Fax. 02-399 0939 E-mail : Sale1@siamhyd.com, website : www.siamhyd.com

SC-100/056-890-L091

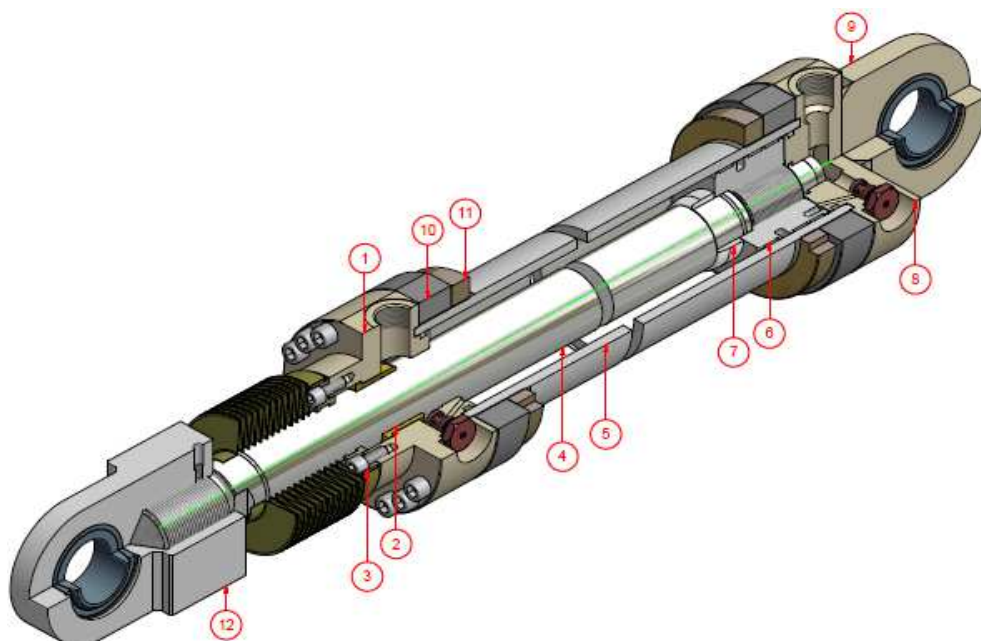

Part List SC-100/056-890-L091

ITEM	P/N	QTY	PART NAME
1	SP-L091-01-01	1	HEAD CYLINDER
2	SP-L091-01-02	1	GUIDE BUSH
3	SP-L091-01-03	1	FRONT COVER
4	SP-L091-02-01	1	ROD
5	SP-L091-03-01	1	TUBE CYLINDER
6	SP-L091-04-01	1	PISTON
7	SP-L091-04-02	1	CUSHION SIEEVE
8	SP-L091-05-01	1	END CYLINDER
9	SP-L091-05-02	1	END MOUNTING
10	SP-L091-06-01	2	FINGE TUBE
11	SP-L091-06-02	2	LOCKING RING
12	SP-L091-06-03	1	MOUNTING ROD

รูปชิ้นส่วนที่ผลิต (Job.N028)



Head Cylinder



Guide Bush



Front Cover



Rod



Tube Cylinder



Piston



Cushion Sleeve



End Cylinder



End Mounting



Flange Tube



Locking Ring



Mounting Rod



Bellow



Screw Set



Cushion Valve



Bearing Set



Seal Kit

ภาพการประกอบและทดสอบ Hydraulic Test (Job.N028)

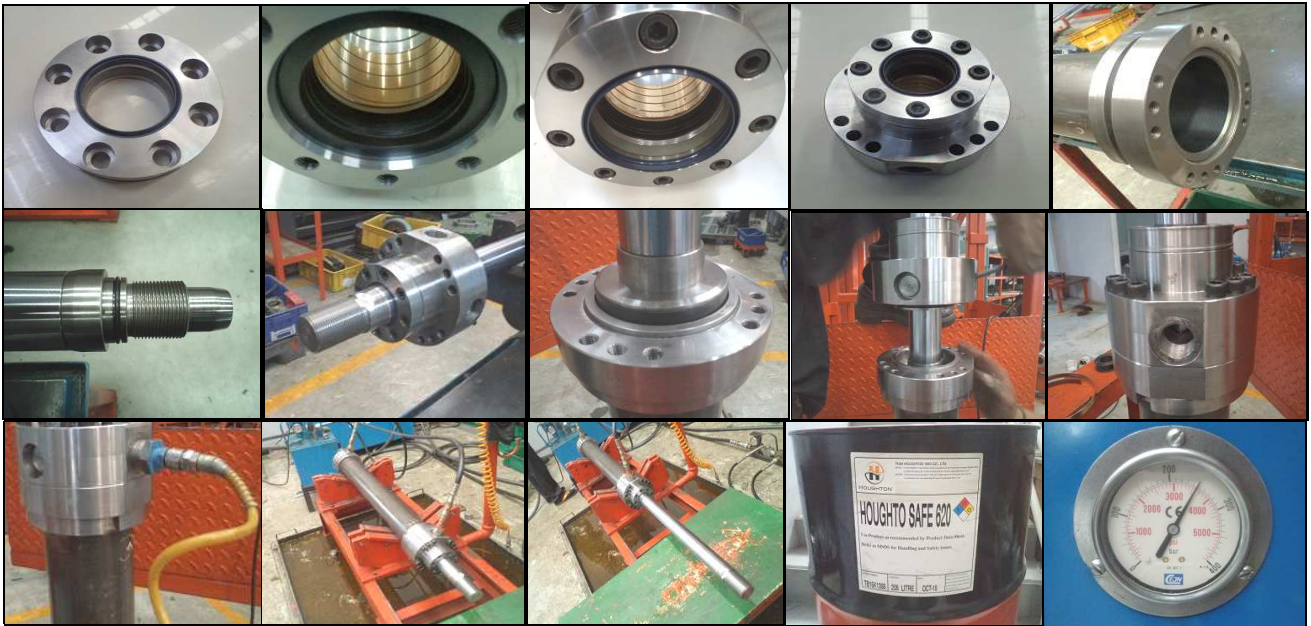

HYDRAULIC TEST REPORT

CUSTOMER NAME:

PROJECT NO.: SC-100/056-890-L091

TYPE: 100x56x890

REF. P/O NO. : -

DATE: -

QUOTATION NO. :-

DATE: -

QUALITY: 1 Set

DELIVERY DATE: -

TEST PRESSURE

WORKING PRESSURE: 140 Bar

MAXIMUM TEST: 250 Bar

TESTING TIME: 30 Minute

TEST BY
.....
SERVICES TECHNICIAN

INSPECTION BY
.....
ENGINEER

SIAM HYD

Siam Hydraulic Co.,Ltd

High quality cylinders for heavy duty application