

HYDRAULIC CYLINDER

“SC-100/056-28-N102”

Production Report For Mechanical Maintenance

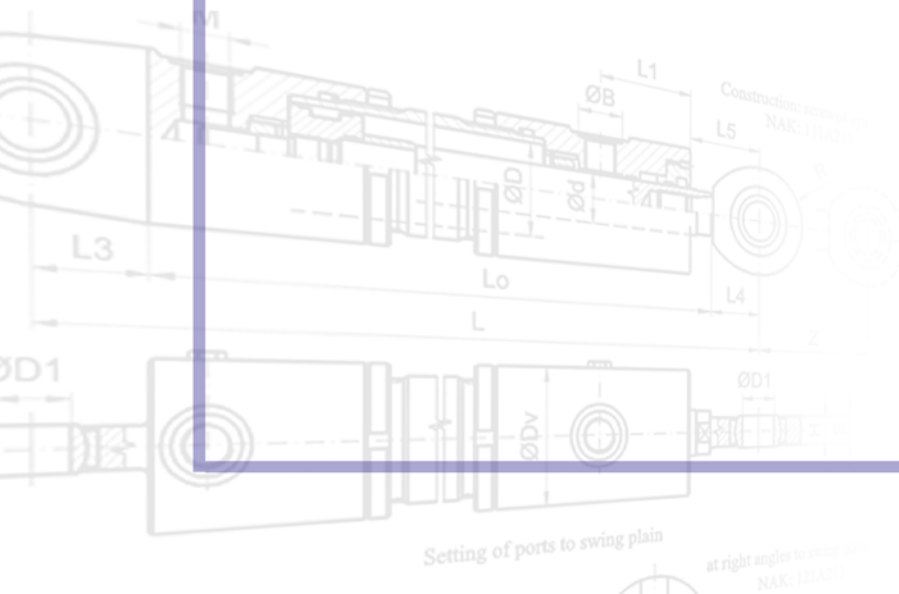
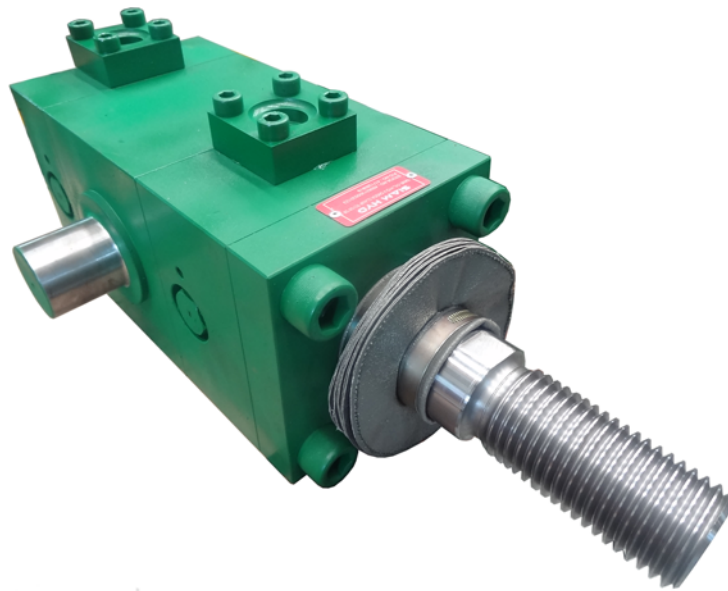

Job.N102

Hydraulic Cylinder “SC-100/056-28-N102”

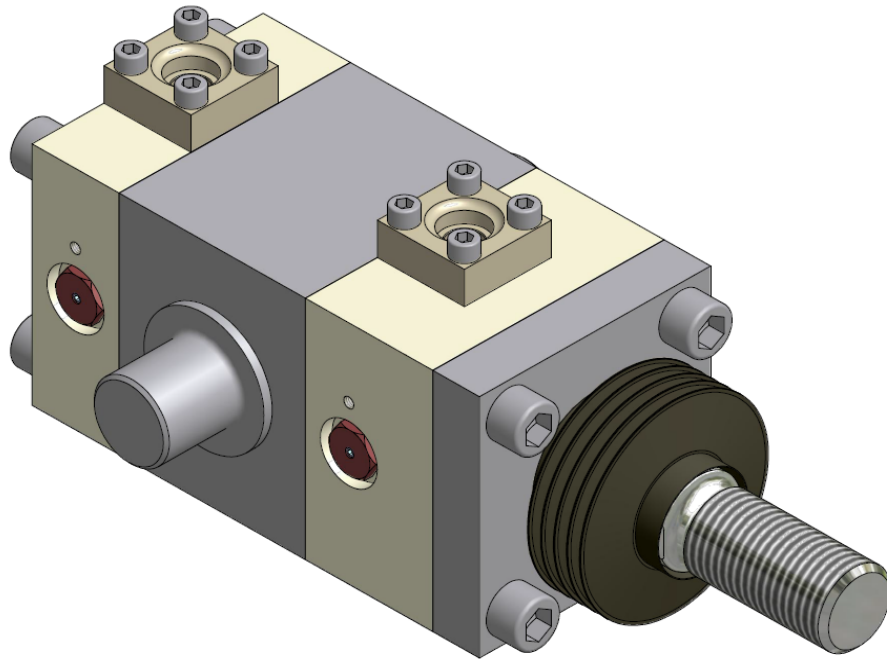

Hydraulic Cylinder 100x56x28

Bore size: Ø100 mm.

Rod size: Ø56 mm.

Stroke: 28 mm.

Working Pressure: 140 Bar

SR No. : 61/107

Job No. : N0102



Siam Hydraulic Co.,Ltd.

888 Lasalle Road, Bangna Tai, Bangna, Bangkok 10260

Tel./Fax. 02-399 0939 E-mail : Sale1@siamhyd.com, website : www.siamhyd.com

SC-100/056-28-N102

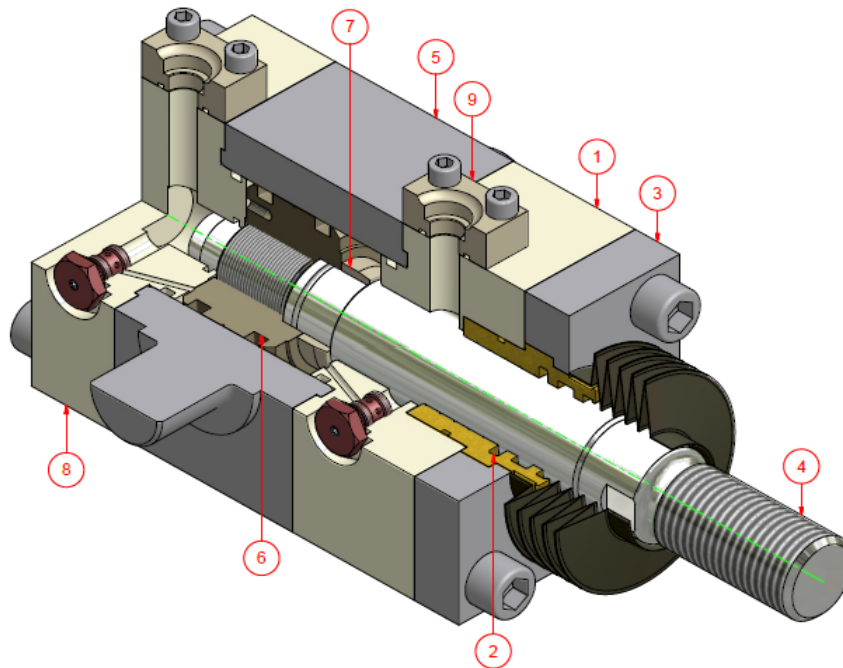

Part List SC-100/056-28-N102

ITEM	P/N	QTY	PART NAME
1	SP-N102-01-01	1	HEAD CYLINDER
2	SP-N102-01-02	1	GLAND
3	SP-N102-01-03	1	FRONT COVER
4	SP-N102-02-01	1	ROD
5	SP-N102-03-01	1	TUBE CYLINDER
6	SP-N102-04-01	1	PISTON
7	SP-N102-04-02	1	CUSHION SLEEVE
8	SP-N102-05-01	1	END CYLINDER
9	SP-N102-06-01	2	FLANGE SSA - 20

รูปชิ้นส่วนที่ผลิต (Job.N102)

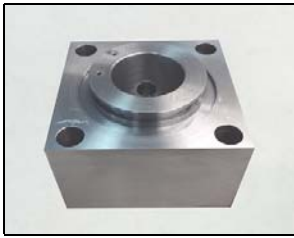

Head Cylinder



Gland

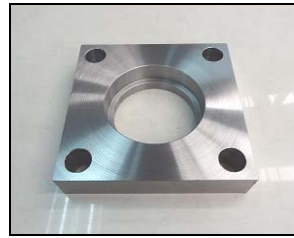

Front Cover



Rod

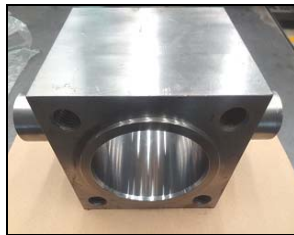

Tube Cylinder



Piston



Cushion sleeve



End Cylinder



Flange SSA-20



Cushion Valve



Screw Set



Bellows



Seal Kit

ภาพการผลิต , ประกอบ และ ทดสอบ Hydraulic Test (Job.N102)



HYDRAULIC TEST REPORT

CUSTOMER NAME:

PROJECT NO.: **SC-100/056-28-N102**

TYPE: **100x56x28**

REF. P/O NO. : -

DATE: -

QUOTATION NO. :-

DATE: -

QUALITY: **1 Set**

DELIVERY DATE: -

TEST PRESSURE

WORKING PRESSURE: **140 Bar**

MAXIMUM TEST: **250 Bar**

TESTING TIME: **30 Minute**

TEST BY

.....
SERVICES TECHNICIAN

INSPECTION BY

.....
ENGINEER



Siam Hydraulic Co.,Ltd.

888 Lasalle Road, Bangna Tai, Bangna, Bangkok 10260

Tel./Fax. 02-399 0939 E-mail : Sale1@siamhyd.com, website : www.siamhyd.com

SIAM HYD

Siam Hydraulic Co.,Ltd

High quality cylinders for heavy duty application