

HYDRAULIC CYLINDER “SC-090/060-560-N020”

Production Report For Mechanical Maintenance



Job.N020

www.siamhyd.com

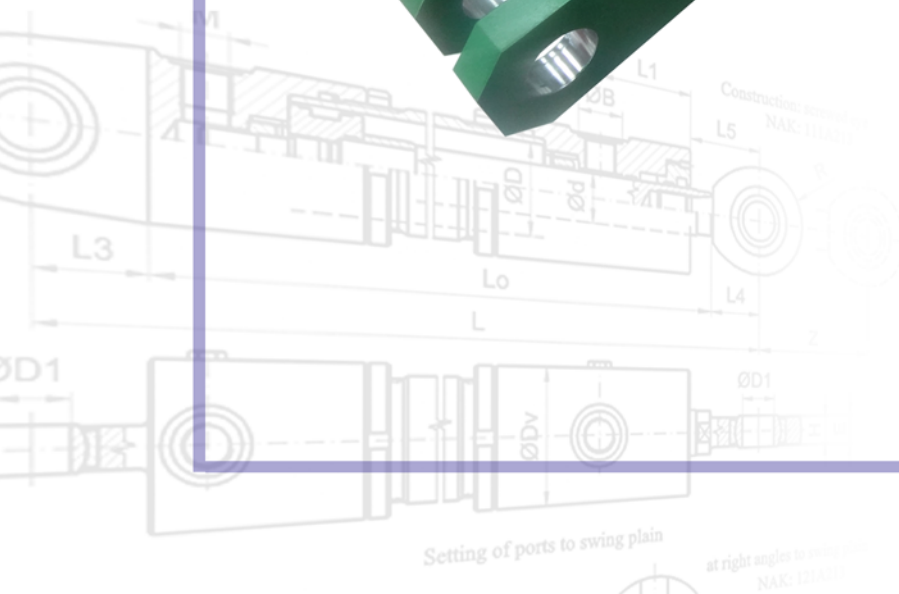

Hydraulic Cylinder “SC-090/060-560-N020”

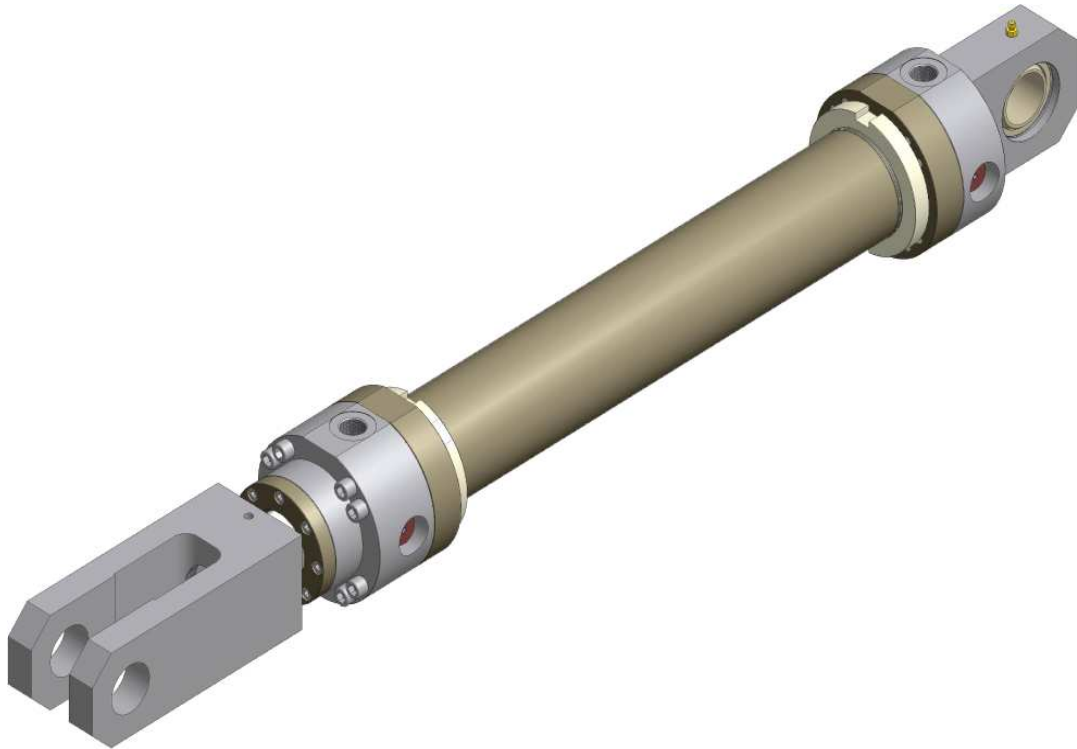

Hydraulic Cylinder 090x060x560

Bore size: $\varnothing 90$ mm.

Rod size: $\varnothing 60$ mm.

Stroke: 560 mm.

Working Pressure: 140 Bar

SR No. : 61/021

Job No. : N020 (No.1,2)



Siam Hydraulic Co.,Ltd.

888 Lasalle Road, Bangna Tai, Bangna, Bangkok 10260

Tel./Fax. 02-399 0939 E-mail : Sale1@siamhyd.com, website : www.siamhyd.com

SC-090/060-560-N020

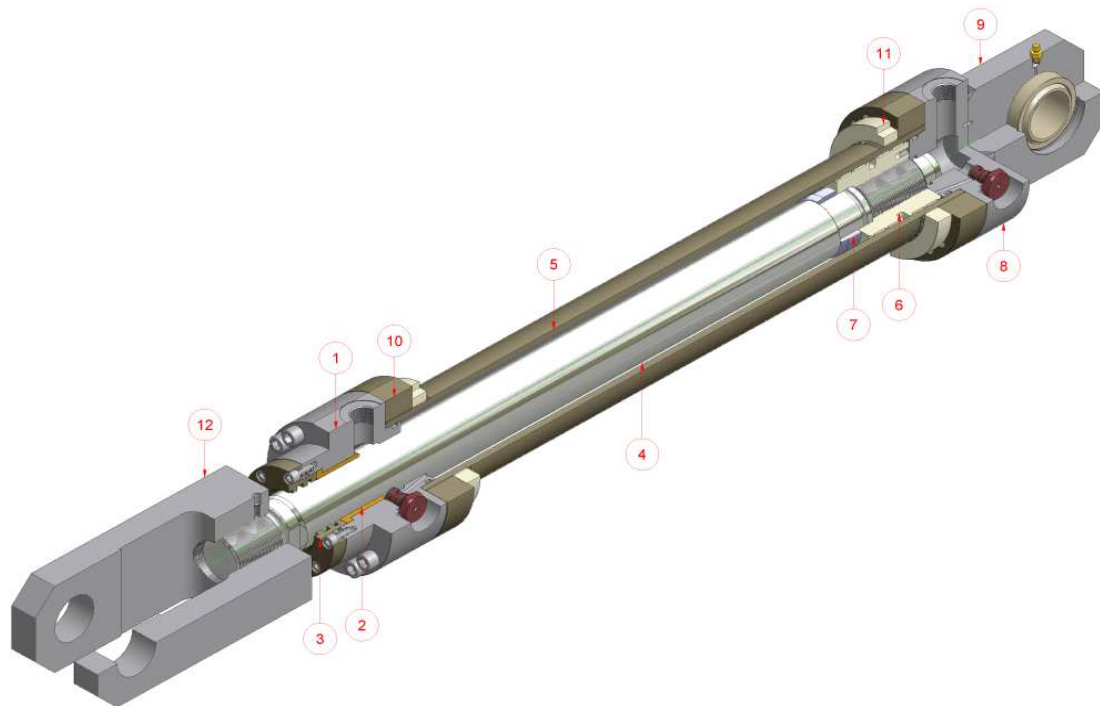

Part List SC-090/060-560-N020

ITEM	P/N	QTY	PART NAME
1	SP-N020-01-01	1	HEAD CYLINDER
2	SP-N020-01-02	1	GUIDE BUSH
3	SP-N020-01-03	1	FRONT COVER
4	SP-N020-02-01	1	ROD
5	SP-N020-03-01	1	TUBE CYLINDER
6	SP-N020-04-01	1	PISTON
7	SP-N020-04-02	1	CUSHION SIEEVE
8	SP-N020-05-01	1	END CYLINDER
9	SP-N020-05-02	1	END MOUNTING
10	SP-N020-06-01	2	FINGE TUBE
11	SP-N020-06-02	2	LOCKING RING
12	SP-N020-06-03	1	MOUNTING ROD

รูปชิ้นส่วนที่ผลิต (Job.N020)



Head Cylinder



Guide Bush



Front Cover



Rod



Tube Cylinder

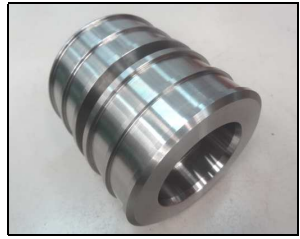

Piston



Cushion Sleeve



End Cylinder

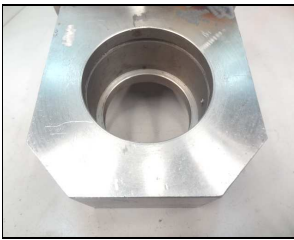

End Mounting



Flange Tube



Locking Ring



Mounting Rod



Screw Set



Cushion Valve



Bearing Set



Seal Kit

ภาพการผลิต,ประกอบ และทดสอบ Hydraulic Test (Job.N020)



HYDRAULIC TEST REPORT

CUSTOMER NAME:

PROJECT NO.: SC-090/060-560-N020

TYPE: 090x60x560

REF. P/O NO. : -

DATE: -

QUOTATION NO. :-

DATE: -

QUALITY: 2 Set

DELIVERY DATE: -

TEST PRESSURE

WORKING PRESSURE: 140 Bar

MAXIMUM TEST: 250 Bar

TESTING TIME: 30 Minute

TEST BY

SERVICES TECHNICIAN

INSPECTION BY

ENGINEER

SIAM HYD

Siam Hydraulic Co.,Ltd

High quality cylinders for heavy duty application