

HYDRAULIC CYLINDER “SC-082.6/044.5-530-L009”

Production Report For Mechanical Maintenance

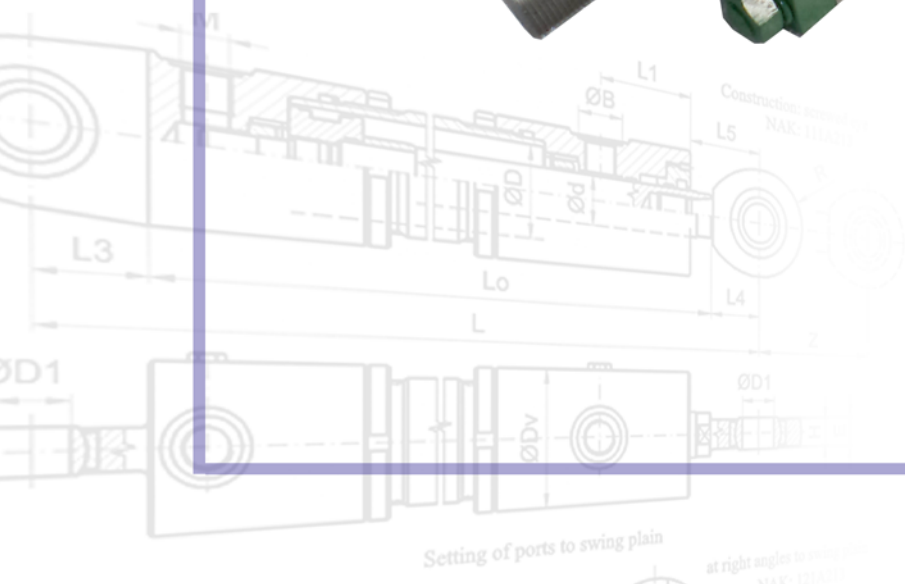

Job.L009

Hydraulic Cylinder “SC-082.6/044.5-530-L009”



Hydraulic Cylinder 82.6x44.5x530

Bore size: **Ø82.6 mm.**

Rod size: **Ø44.5 mm.**

Stroke: **530 mm.**

Working Pressure: **140 Bar**

SR No. : **59/016**

Job No. : **L009**



Siam Hydraulic Co.,Ltd.

888 Lasalle Road, Bangna Tai, Bangna, Bangkok 10260

Tel./Fax. 02-399 0939 E-mail : Sale1@siamhyd.com, website : www.siamhyd.com

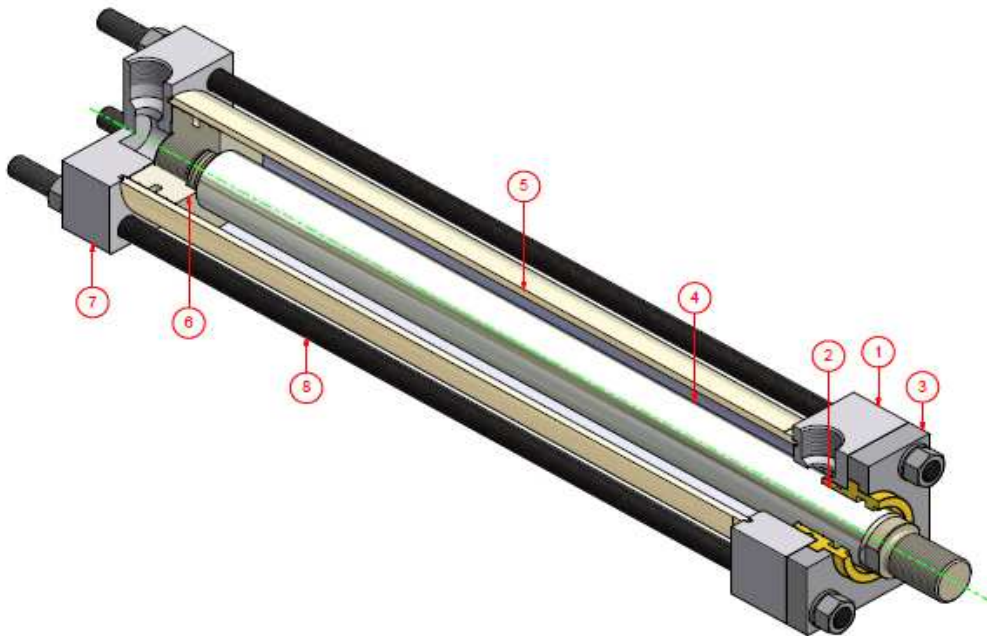

Part List SC-082.6/044.5-530-L009

ITEM	P/N	QTY	PART NAME
1	SP-L009-01-01	1	HEAD CYLINDER
2	SP-L009-01-02	1	GLAND
3	SP-L009-01-03	1	FRONT COVER
4	SP-L009-02-01	1	ROD
5	SP-L009--03-01	1	TUBE CYLINDER
6	SP-L009--04-01	1	PISTON
7	SP-L009--05-01	1	END CYLINDER
8	SP-L009--06-01	4	TIE ROD

รูปชิ้นส่วนที่ผลิต (Job.L009)

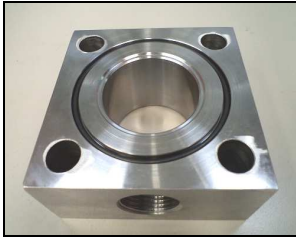

Head Cylinder



Gland



Front Cover



Rod



Tube Cylinder



Piston



End Cylinder



Tie Rod



Nuts Set



Seal Kit

ภาพการผลิต,ประกอบและทดสอบ Hydraulic Test (Job.L009)

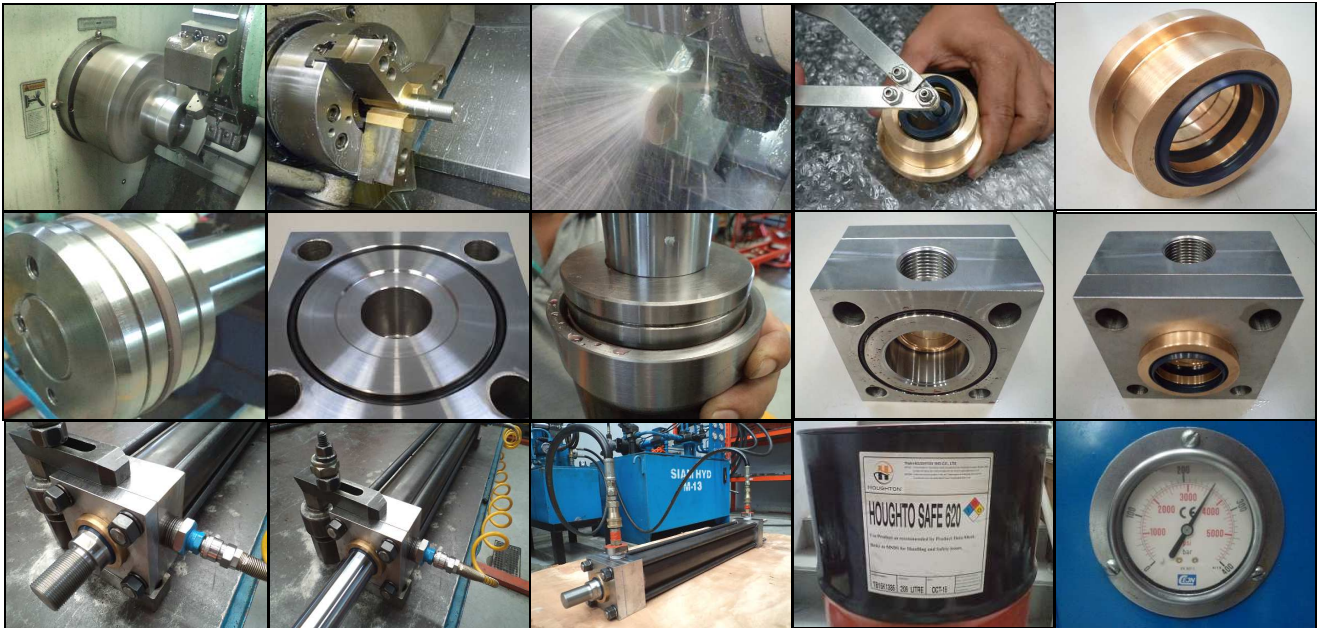

HYDRAULIC TEST REPORT

CUSTOMER NAME:

PROJECT NO.: SC-082.6/044.5-530-L009

TYPE: 82.6x44.5x530

REF. P/O NO. : -

DATE: -

QUOTATION NO. :-

DATE: -

QUALITY: 1 Set

DELIVERY DATE: -

TEST PRESSURE

WORKING PRESSURE: 140 Bar

MAXIMUM TEST: 250 Bar

TESTING TIME: 30 Minute

TEST BY

SERVICES TECHNICIAN

INSPECTION BY

ENGINEER



Siam Hydraulic Co.,Ltd.

888 Lasalle Road, Bangna Tai, Bangna, Bangkok 10260

Tel./Fax. 02-399 0939 E-mail : Sale1@siamhyd.com, website : www.siamhyd.com

SIAM HYD

Siam Hydraulic Co.,Ltd

High quality cylinders for heavy duty application