

High Quality Cylinders For Heavy Duty Application

HYDRAULIC CYLINDER “SC-080/056-1500-L095”

Production Report For Mechanical Maintenance

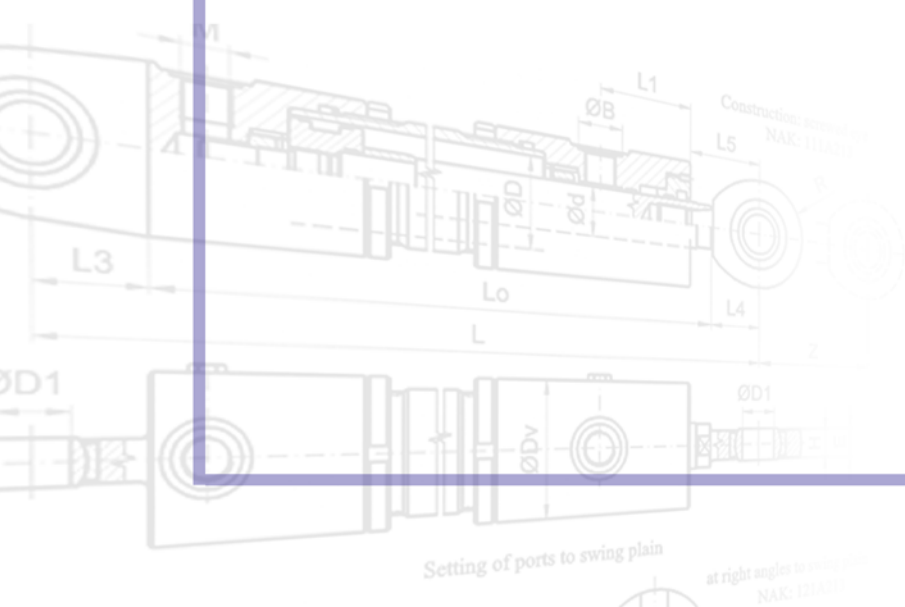

Job.P063

www.siamhyd.com

Hydraulic Cylinder “SC-080/056-1500-L095”

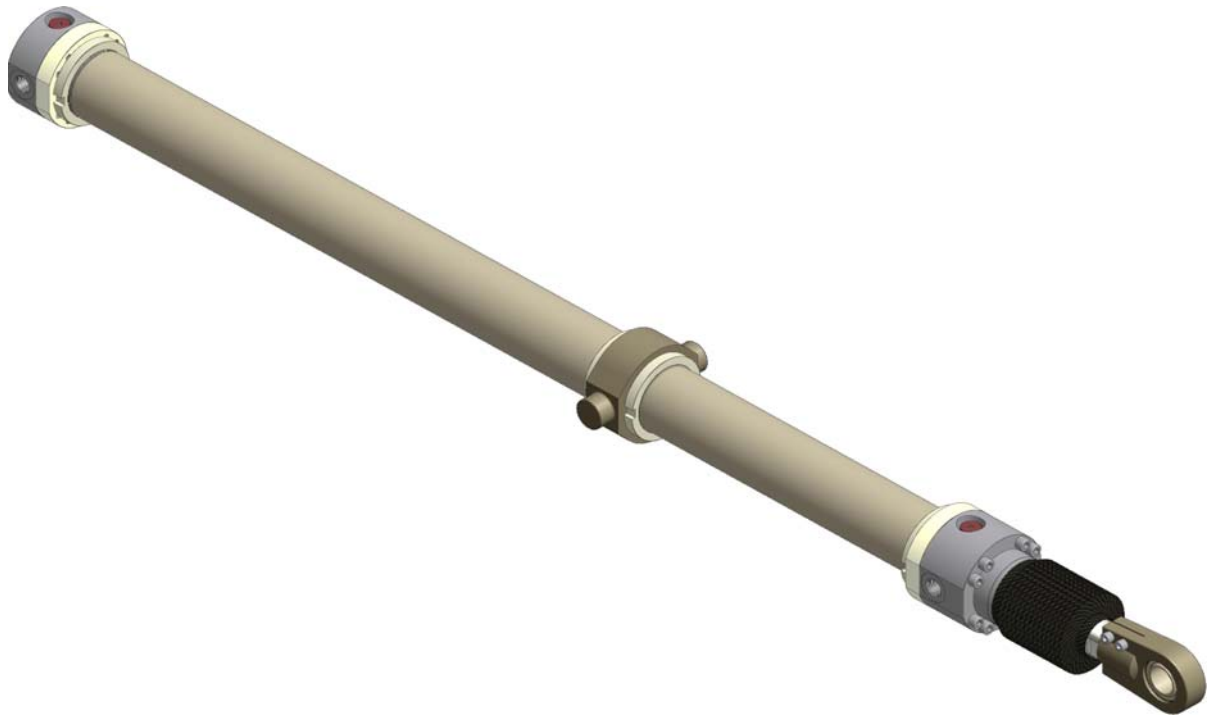

Hydraulic Cylinder 80x56x1500

Bore size: Ø80 mm.

Rod size: Ø56 mm.

Stroke: 1500 mm.

Working Pressure: 140 Bar

SR No. : 62/069

Job No. : P063



Siam Hydraulic Co.,Ltd.

888 Lasalle Road, Bangna Tai, Bangna, Bangkok 10260

Tel./Fax. 02-399 0939 E-mail : Sale1@siamhyd.com, website : www.siamhyd.com

SC-080/056-1500-L095

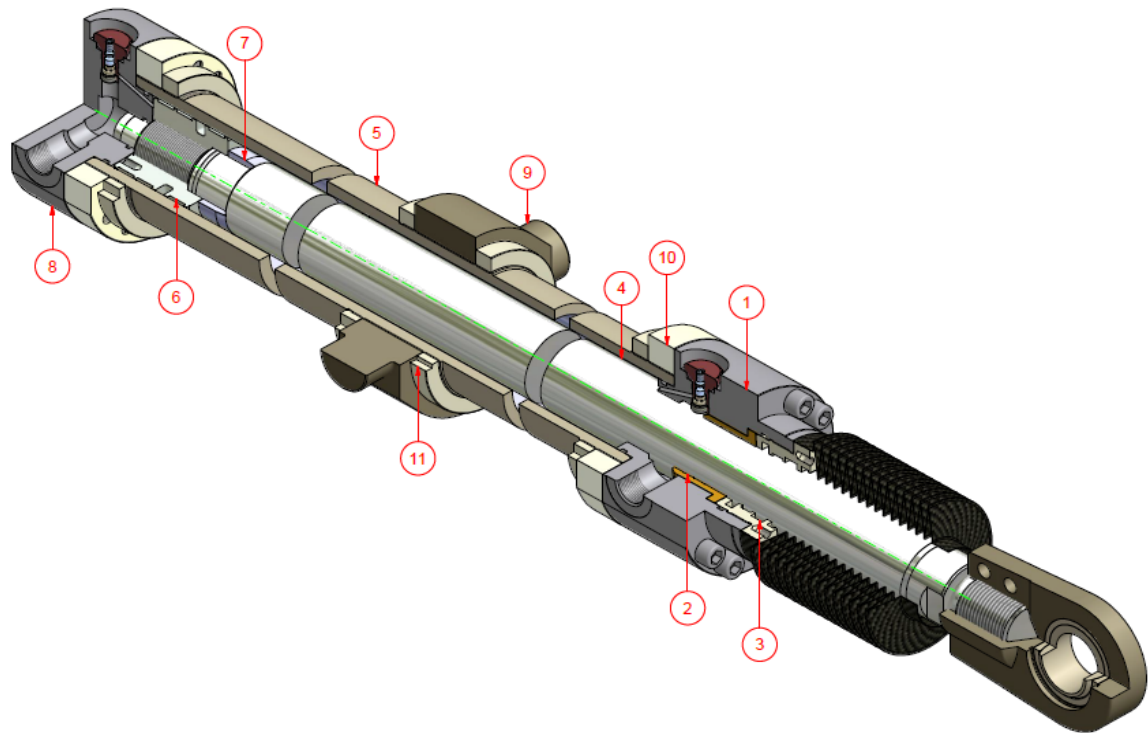

Part List SC-080/056-1500-L095

ITEM	P/N	QTY	PART NAME
1	SP-L095-01-01	1	HEAD CYLINDER
2	SP-L095-01-02	1	GUIDE BUSH
3	SP-L095-01-03	1	GLAND
4	SP-L095-02-01	1	ROD
5	SP-L095-03-01	1	TUBE CYLINDER
6	SP-L095-04-01	1	PISTON
7	SP-L095-04-02	1	CUSHION SLEEVE
8	SP-L095-05-01	1	END CYLINDER
9	SP-L095-06-01	1	TRUNNION
10	SP-L095-06-02	2	FLANGE TUBE
11	SP-L095-06-03	4	LOCKING RING

รูปชิ้นส่วนที่ผลิต (Job.P063)



Head Cylinder



Guide Bush



Gland



Rod



Tube Cylinder



Piston



Cushion sleeve



End Cylinder



Trunnion



Flange Tube



Locking Ring



Mounting Rod



Bellow



Cushion Valve



Screw Set



Seal Kit

ภาพการประกอบและทดสอบ Hydraulic Test (Job.P063)



HYDRAULIC TEST REPORT

CUSTOMER NAME:

PROJECT NO.: SC-080/056-1500-L095

REF. P/O NO. : -

QUOTATION NO. :-

QUALITY: 1 Set

TYPE: 80x56x1500

DATE: -

DATE: -

DELIVERY DATE: -

TEST PRESSURE

WORKING PRESSURE: 140 Bar

MAXIMUM TEST: 250 Bar

TESTING TIME: 30 Minute

TEST BY
SERVICES TECHNICIAN

INSPECTION BY
ENGINEER

SIAM HYD

Siam Hydraulic Co.,Ltd

High quality cylinders for heavy duty application