

HYDRAULIC CYLINDER

“SC-080/050-1500-M106”

Production Report For Mechanical Maintenance



Job.M106

Hydraulic Cylinder “SC-080/050-1500-M106”

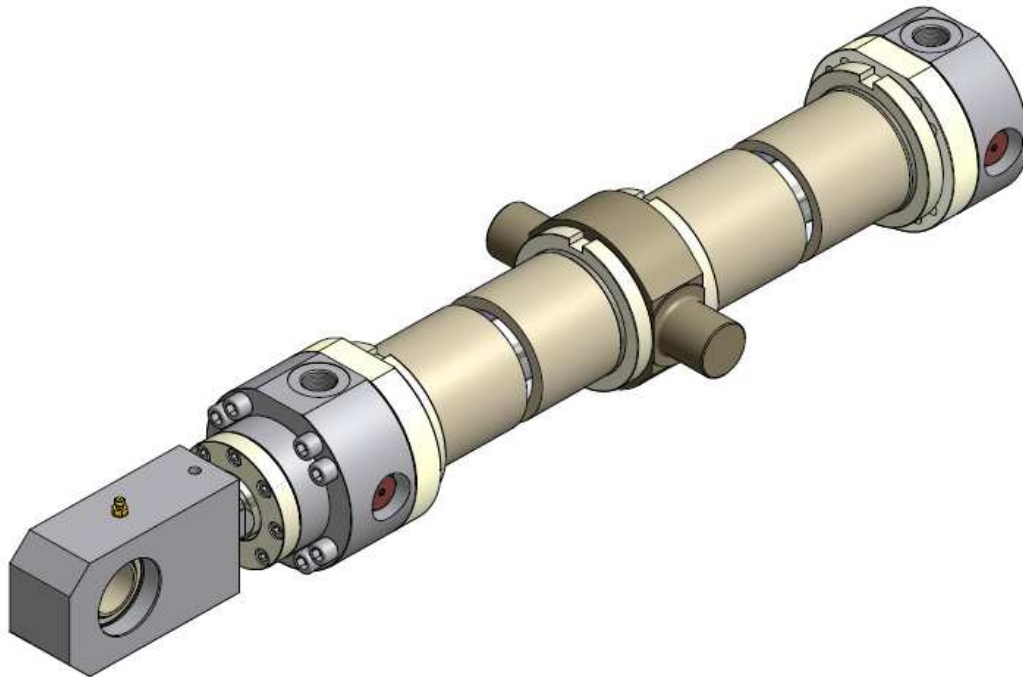

Hydraulic Cylinder 80x50x1500

Bore size: **Ø80 mm.**

Rod size: **Ø50 mm.**

Stroke: **1500 mm.**

Working Pressure: **140 Bar**

SR No. : **60/108**

Job No. : **M106**

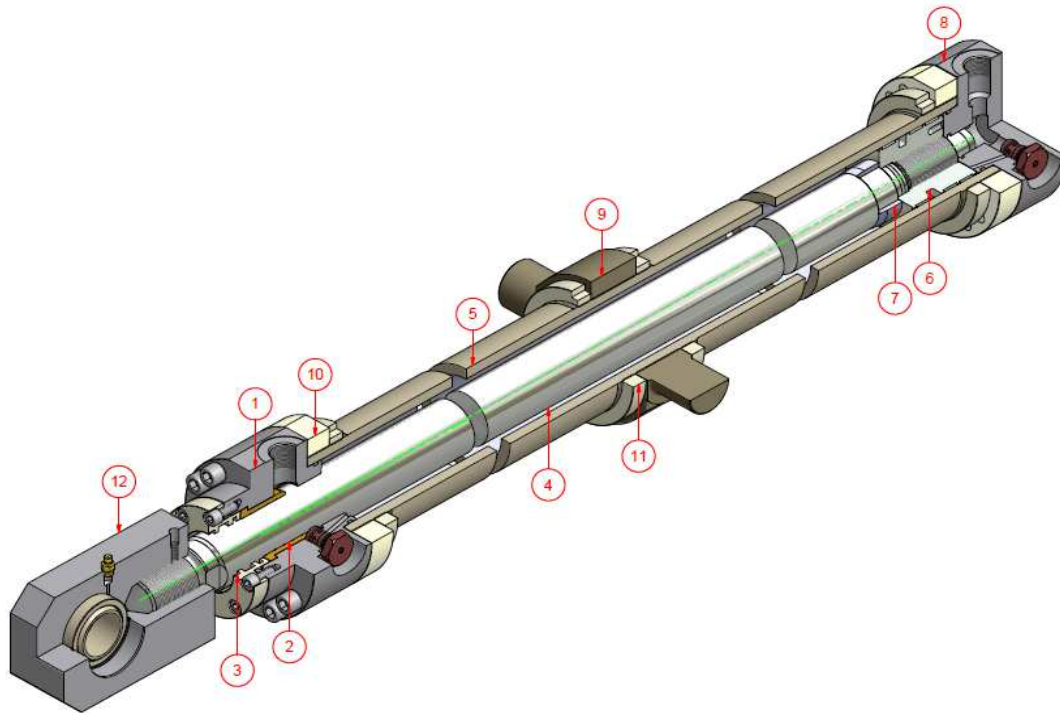

Part List SC-080/050-1500-M106

ITEM	P/N	QTY	PART NAME
1	SP-M106-01-01	1	HEAD CYLINDER
2	SP-M106-01-02	1	GUIDE BUSH
3	SP-M106-01-03	1	FRONT COVER
4	SP-M106-02-01	1	ROD
5	SP-M106-03-01	1	TUBE CYLINDER
6	SP-M106-04-01	1	PISTON
7	SP-M106-04-02	1	CUSHION SLEEVE
8	SP-M106-05-01	1	END CYLINDER
9	SP-M106-06-01	1	TRUNNION
10	SP-M106-06-02	2	FLANGE TUBE
11	SP-M106-06-03	4	LOCKING RING
12	SP-M106-06-04	1	MOUNTING ROD

รูปชิ้นส่วนที่ผลิต (Job.M106)



Head Cylinder



Guide Bush



Front Cover



Rod

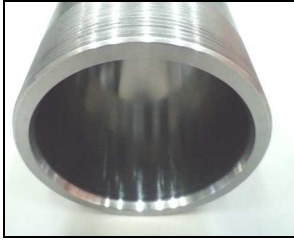

Tube Cylinder



Piston



Cushion Sleeve



End Cylinder



Trunnion



Flange Lock



Locking Ring



Mounting Rod



Screws Set



Cushion Valve



Bearings Set



Seal Kit

ภาพการผลิต,ประกอบและทดสอบ Hydraulic Test (Job.M106)



HYDRAULIC TEST REPORT

CUSTOMER NAME:

PROJECT NO.: SC-080/050-1500-M106

TYPE: 80x50x1500

REF. P/O NO. : -

DATE: -

QUOTATION NO. :-

DATE: -

QUALITY: 1 Set

DELIVERY DATE: -

TEST PRESSURE

WORKING PRESSURE: 140 Bar

MAXIMUM TEST: 250 Bar

TESTING TIME: 30 Minute

TEST BY _____
SERVICES TECHNICIAN

INSPECTION BY _____
ENGINEER



Siam Hydraulic Co.,Ltd.

888 Lasalle Road, Bangna Tai, Bangna, Bangkok 10260

Tel./Fax. 02-399 0939 E-mail : Sale1@siamhyd.com, website : www.siamhyd.com

SIAM HYD

Siam Hydraulic Co.,Ltd

High quality cylinders for heavy duty application