

## HYDRAULIC CYLINDER “SC-080/050-150-K043”

Production Report For Mechanical Maintenance



Job.N064

## *Hydraulic Cylinder “SC-080/050-150-K043”*

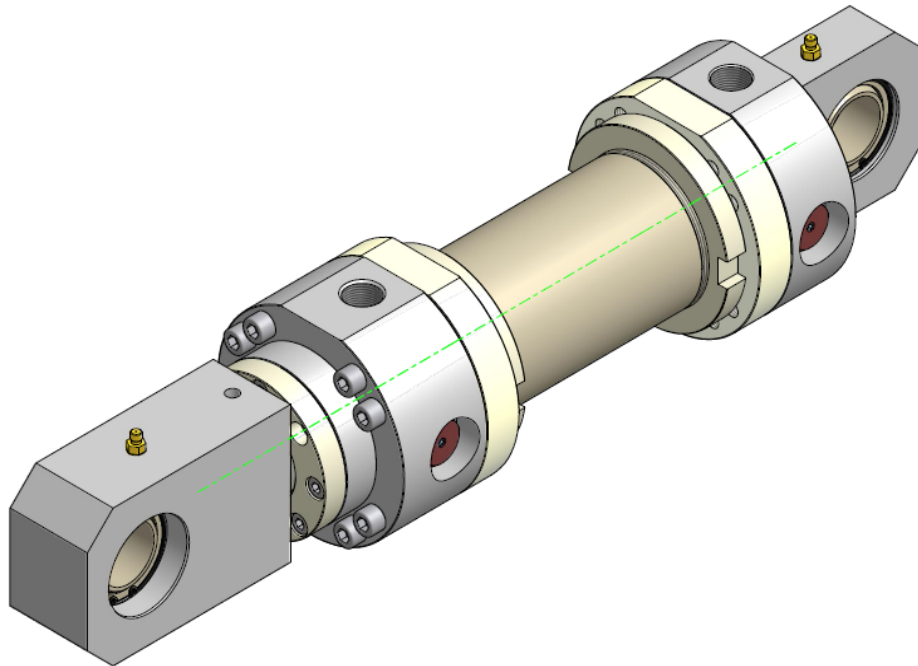

### *Hydraulic Cylinder 80x50x150*

Bore size: **Ø80 mm.**

Rod size: **Ø50 mm.**

Stroke: **150 mm.**

Working Pressure: **140 Bar**

SR No. : **61/073**

Job No. : **N064**

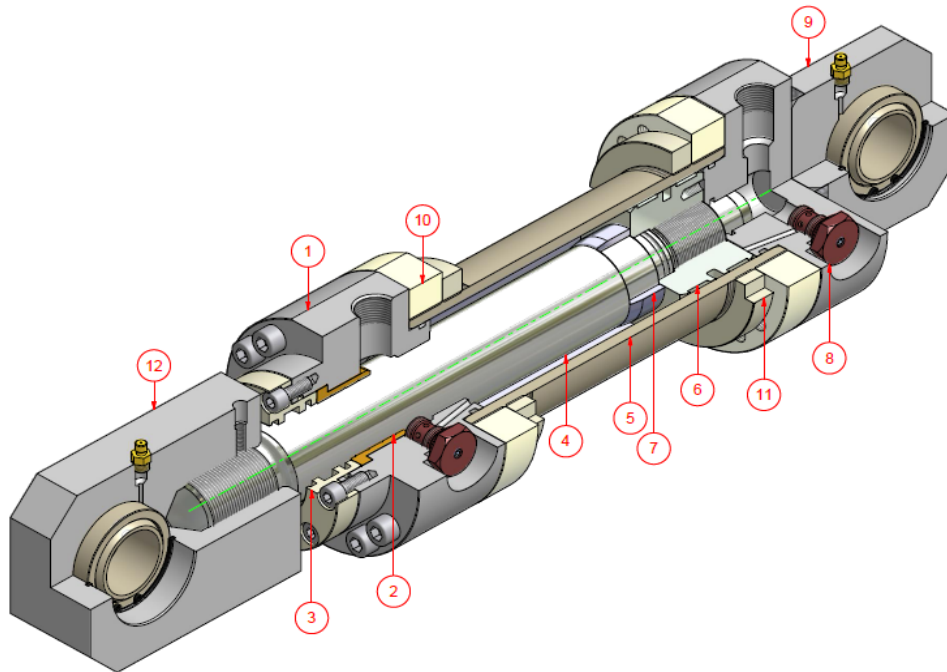

**Part List SC-080/050-150-K043**

ITEM	P/N	QTY	PART NAME
1	SP-K043-01-01	1	HEAD CYLINDER
2	SP-K043-01-02	1	GUIDE BUSH
3	SP-K043-01-03	1	FRONT COVER
4	SP-K043-02-01	1	ROD
5	SP-K043-03-01	1	TUBE CYLINDER
6	SP-K043-04-01	1	PISTON
7	SP-K043-04-02	1	CUSHION SLEEVE
8	SP-K043-05-01	1	END CYLINDER
9	SP-K043-05-02	1	END MOUNTING
10	SP-K043-06-01	2	FLANGE TUBE
11	SP-K043-06-03	2	LOCKING RING
12	SP-K043-06-02	1	MOUNTING ROD

# รูปชิ้นส่วนที่ผลิต Job.N064

---



Head Cylinder



Guide Bush



Front Cover



Rod

---



Tube Cylinder



Piston



Cushion Sleeve



End Cylinder

---

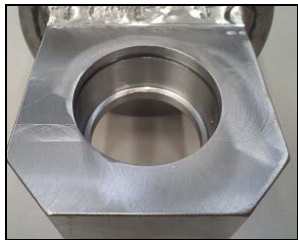

End Mounting



Flange Lock



Locking Ring



Mounting Rod

---



Screws Set



Cushion Valve



Bearings Set



Seal Kit

---





### HYDRAULIC TEST REPORT

CUSTOMER NAME:

PROJECT NO.: SC-080/050-150-K043

TYPE: 80x50x150

REF. P/O NO. : -

DATE: -

QUOTATION NO. :-

DATE: -

QUALITY: 1 Set

DELIVERY DATE: -

### TEST PRESSURE

WORKING PRESSURE: 140 Bar

MAXIMUM TEST: 250 Bar

TESTING TIME: 30 Minute

TEST BY \_\_\_\_\_  
SERVICES TECHNICIAN

INSPECTION BY \_\_\_\_\_  
ENGINEER



**Siam Hydraulic Co.,Ltd.**

888 Lasalle Road, Bangna Tai, Bangna, Bangkok 10260

Tel./Fax. 02-399 0939 E-mail : Sale1@siamhyd.com, website : www.siamhyd.com

SIAM HYD

**Siam Hydraulic Co.,Ltd**

High quality cylinders for heavy duty application