

HYDRAULIC CYLINDER “SC-063/045-250-M051”

Production Report For Mechanical Maintenance



Job.N075

www.siamhyd.com

Hydraulic Cylinder “SC-063/045-250-M051”

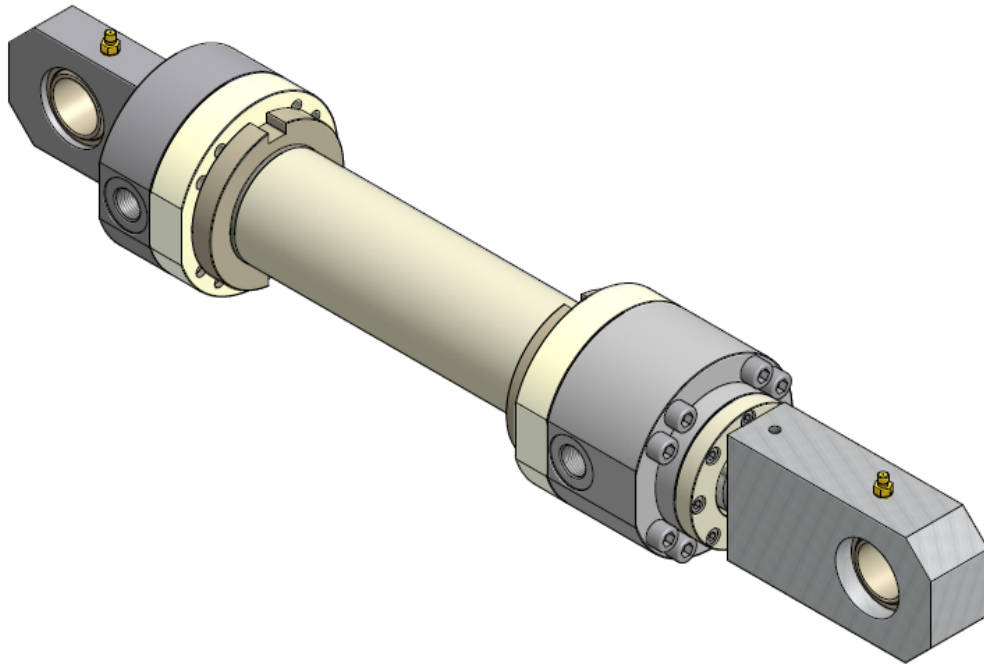

Hydraulic Cylinder 63x45x250

Bore size: Ø63 mm.

Rod size: Ø45 mm.

Stroke: 250 mm.

Working Pressure: 140 Bar

SR No. : 61/055

Job No. : N075



Siam Hydraulic Co.,Ltd.

888 Lasalle Road, Bangna Tai, Bangna, Bangkok 10260

Tel./Fax. 02-399 0939 E-mail : Sale1@siamhyd.com, website : www.siamhyd.com

SC-063/045-250-M051

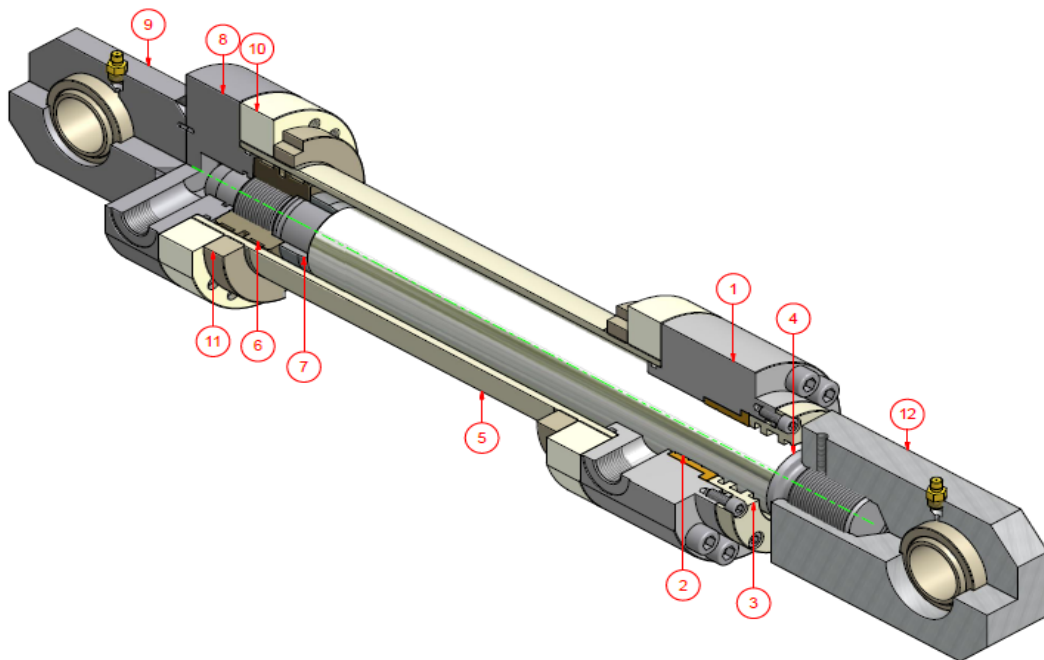

Part List SC-063/045-250-M051

ITEM	P/N	QTY	PART NAME
1	SP-M051-01-01	1	HEAD CYLINDER
2	SP-M051-01-02	1	GUIDE BUSH
3	SP-M051-01-03	1	FRONT COVER
4	SP-M051-02-01	1	ROD
5	SP-M051-03-01	1	TUBE CYLINDER
6	SP-M051-04-01	1	PISTON
7	SP-M051-04-02	1	CUSHION SLEEVE
8	SP-M051-05-01	1	END CYLINDER
9	SP-M051-05-02	1	END MOUNTING
10	SP-M051-06-01	2	FLANGE TUBE
11	SP-M051-06-02	2	LOCKING RING
12	SP-M051-06-03	1	MOUNTING ROD

รูปชิ้นส่วนที่ผลิต (Job.N075)



Head Cylinder



Guide Bush



Front Cover



Rod



Tube Cylinder



Piston



Cushion sleeve



End Cylinder



End Mounting



Flange Tube



Locking Ring



Mounting Rod



Cushion Valve



Screw Set



Bearings Set



Seal Kit

ภาพการประกอบและทดสอบ Hydraulic Test (Job.N075)



HYDRAULIC TEST REPORT

CUSTOMER NAME:

PROJECT NO.: SC-063/045-250-M051

TYPE: 63x45x250

REF. P/O NO. : -

DATE: -

QUOTATION NO. : -

DATE: -

QUALITY: 1 Set

DELIVERY DATE: -

TEST PRESSURE

WORKING PRESSURE: 140 Bar

MAXIMUM TEST: 250 Bar

TESTING TIME: 30 Minute

TEST BY

INSPECTION BY

SERVICES TECHNICIAN

ENGINEER



Siam Hydraulic Co.,Ltd.

888 Lasalle Road, Bangna Tai, Bangna, Bangkok 10260

Tel./Fax. 02-399 0939 E-mail : Sale1@siamhyd.com, website : www.siamhyd.com

SIAM HYD

Siam Hydraulic Co.,Ltd

High quality cylinders for heavy duty application