

## HYDRAULIC CYLINDER “SC-063/036-50-M055”

Production Report For Mechanical Maintenance



Job.N087

[www.siamhyd.com](http://www.siamhyd.com)

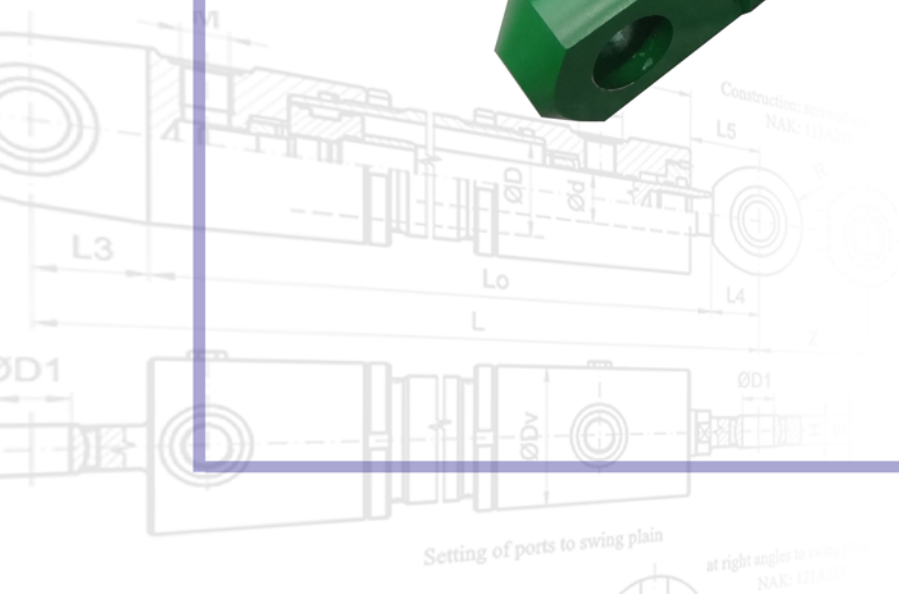

## *Hydraulic Cylinder “SC-063/036-50-M055”*

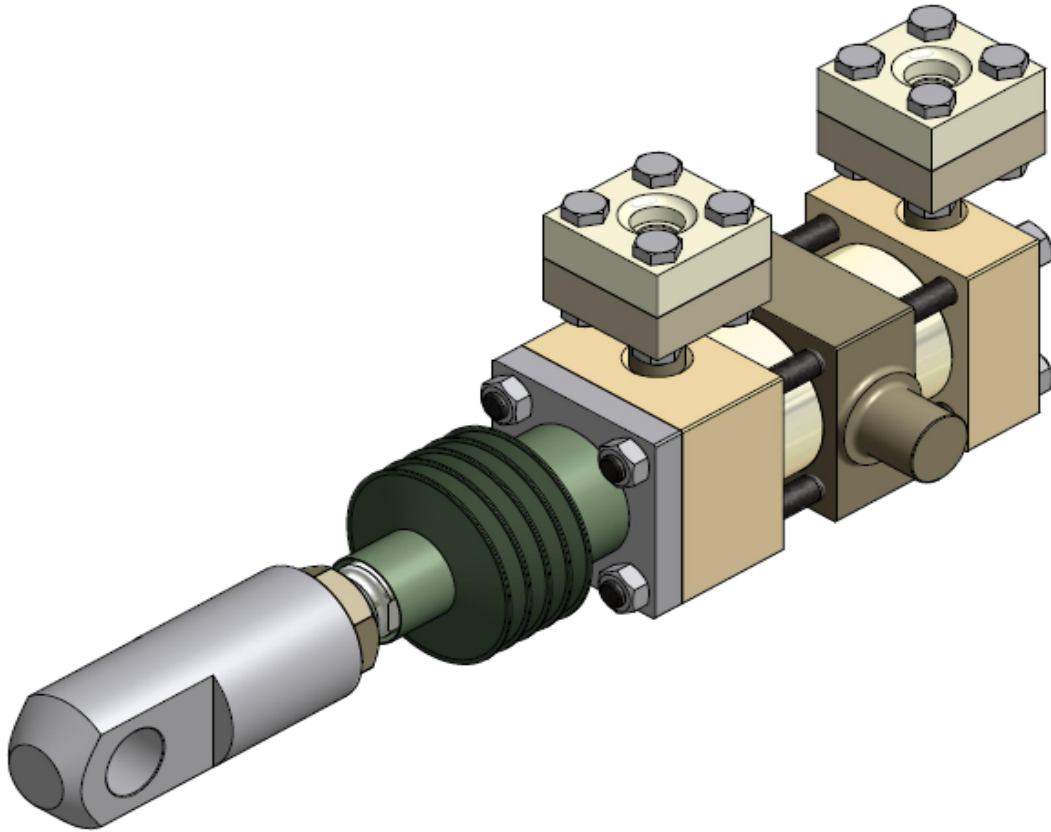

### *Hydraulic Cylinder 63x36x50*

Bore size: **Ø63 mm.**

Rod size: **Ø36 mm.**

Stroke: **50 mm.**

Working Pressure: **140 Bar**

SR No. : **61/087**

Job No. : **N087 (No.1-2)**



**Siam Hydraulic Co.,Ltd.**

888 Lasalle Road, Bangna Tai, Bangna, Bangkok 10260

Tel./Fax. 02-399 0939 E-mail : Sale1@siamhyd.com, website : www.siamhyd.com

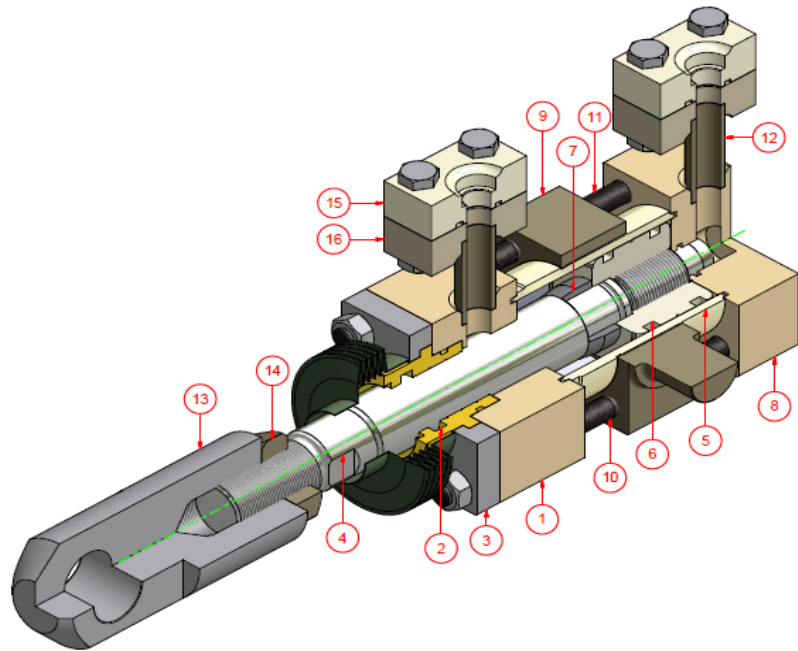

**Part List SC-063/036-50-M055**

ITEM	P/N	QTY	PART NAME
1	SP-M055-01-01	1	HEAD CYLINDER
2	SP-M055-01-02	1	GLAND
3	SP-M055-01-03	1	FRONT COVER
4	SP-M055-02-01	1	ROD
5	SP-M055-03-01	1	TUBE CYLINDER
6	SP-M055-04-01	1	PISTON
7	SP-M055-04-02	1	CUSHION SLEEVE
8	SP-M055-05-01	1	END CYLINDER
9	SP-M055-06-01	1	TRUNNION
10	SP-M055-06-02	4	TIE ROD HEAD
11	SP-M055-06-03	4	TIE ROD END
12	SP-M055-06-04	2	PIPE
13	SP-M055-06-05	1	MOUNTING ROD
14	SP-M055-06-06	1	NUT LOCK
15	SP-M055-06-07	2	FLANGE SHA-15
16	SP-M055-06-08	2	FLANGE SHB-15

## รูปชิ้นส่วนที่ผลิต (Job.N087)

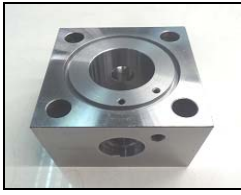

Head Cylinder



Gland

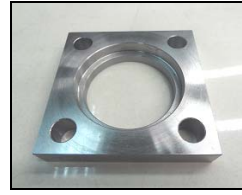

Front Cover



Rod



Tube Cylinder



Piston



Cushion Sleeve



End Cylinder



Trunnion



Tie Rod Head



Tie Rod End



Pipe

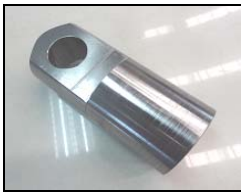

Mounting Rod



Nut Lock

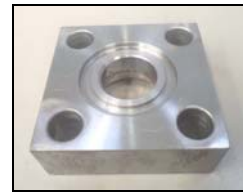

Flange SHA-15



Flange SHB-15



Bellow



Screw Set



Cushion Valve



Seal Kit

## ภาพการประกอบและทดสอบ Hydraulic Test (Job.N087)



### HYDRAULIC TEST REPORT

CUSTOMER NAME:

PROJECT NO.: SC-063/036-50-M055

TYPE: 63x36x50

REF. P/O NO. : -

DATE: -

QUOTATION NO. :-

DATE: -

QUALITY: 2 Set

DELIVERY DATE: -

### TEST PRESSURE

WORKING PRESSURE: 140 Bar

MAXIMUM TEST: 250 Bar

TESTING TIME: 30 Minute

TEST BY \_\_\_\_\_  
SERVICES TECHNICIAN

INSPECTION BY \_\_\_\_\_  
ENGINEER

SIAM HYD

**Siam Hydraulic Co.,Ltd**

High quality cylinders for heavy duty application