

## HYDRAULIC CYLINDER “SC-063/035.5-270-L010”

Production Report For Mechanical Maintenance

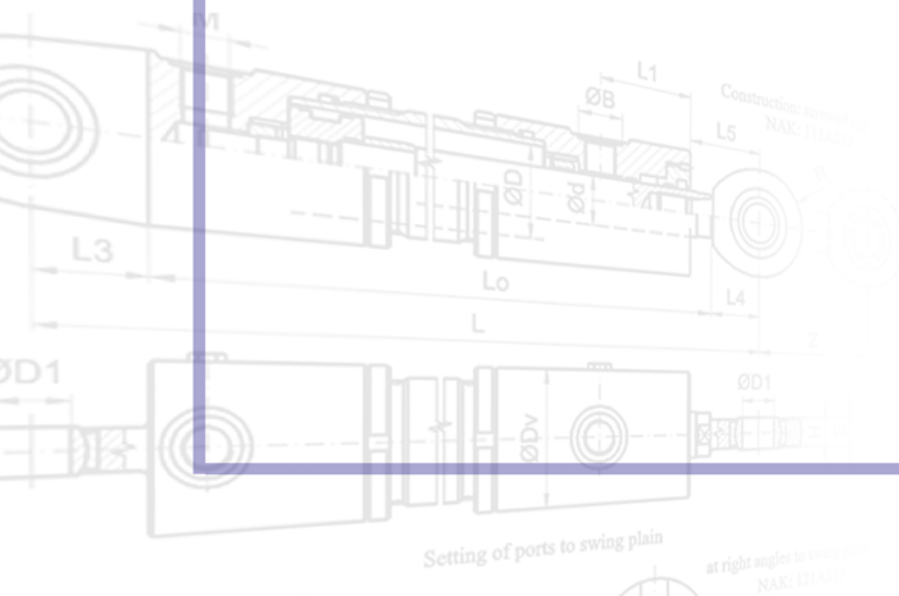

Job.M093

## *Hydraulic Cylinder “SC-063/035.5-270-L010”*

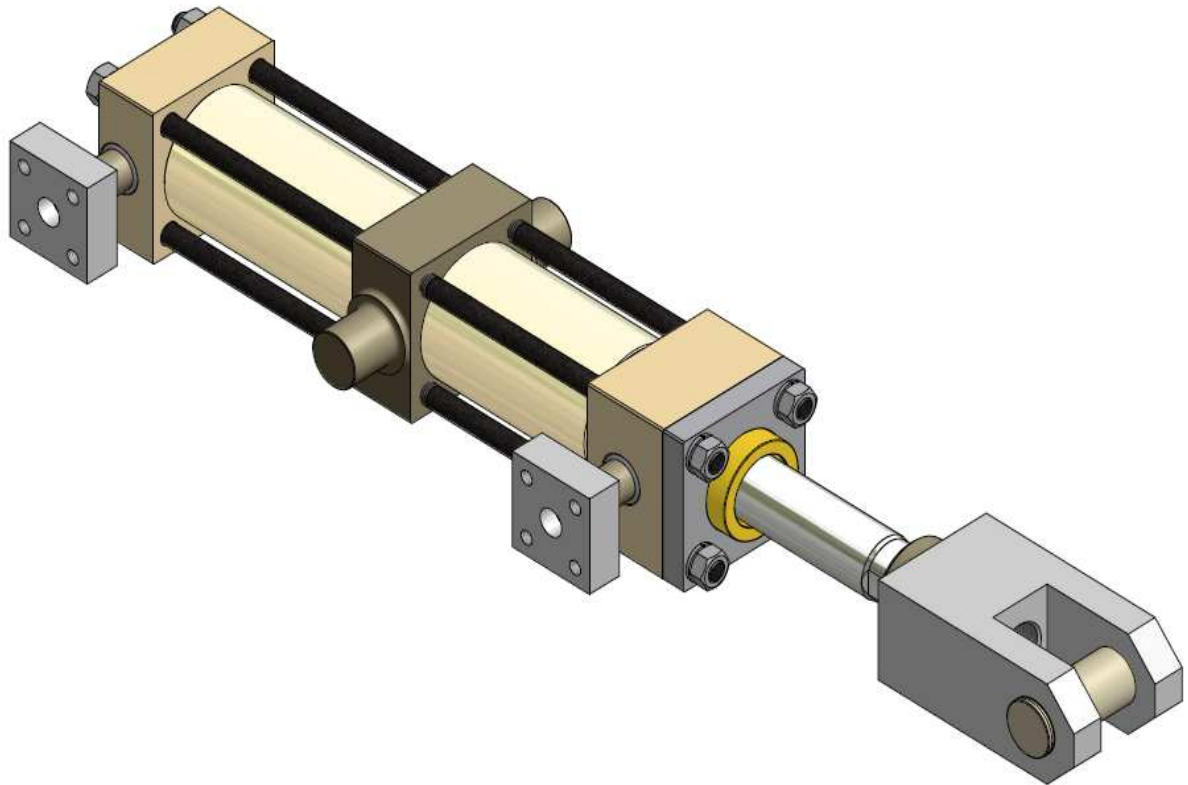

### *Hydraulic Cylinder 63x35.5x270*

Bore size: **Ø63mm.**

Rod size: **Ø35.5 mm.**

Stroke: **270 mm.**

Working Pressure: **140 Bar**

SR No. : **60/102**

Job No. : **M093**

## SC-063/035.5-270-L010

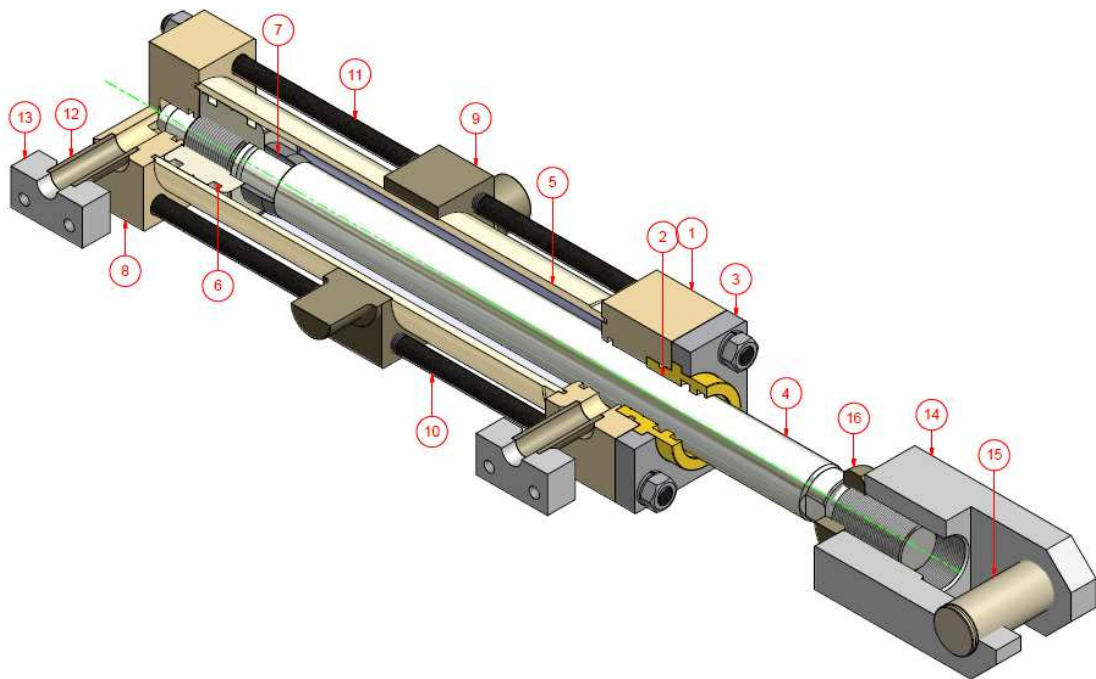

### Part List SC-063/035.5-270-L010

ITEM	P/N	QTY	PART NAME
1	SP-L010-01-01	1	HEAD CYLINDER
2	SP-L010-01-02	1	GLAND
3	SP-L010-01-03	1	FRONT COVER
4	SP-L010-02-01	1	ROD
5	SP-L010-03-01	1	TUBE CYLINDER
6	SP-L010-04-01	1	PISTON
7	SP-L010-04-02	1	CUSHION SLEEVE
8	SP-L010-05-01	1	END CYLINDER
9	SP-L010-06-01	1	TRUNNION
10	SP-L010-06-02	4	TIE ROD HEAD
11	SP-L010-06-03	4	TIE ROD END
12	SP-L010-06-04	2	PIPE
13	SP-L010-06-05	2	FLANGE SSB15
14	SP-L010-06-07	1	MOUNTING ROD
15	SP-L010-06-08	1	PIN
16	SP-L010-06-09	1	LOCK NUT



### **Siam Hydraulic Co.,Ltd.**

888 Lasalle Road, Bangna Tai, Bangna, Bangkok 10260

Tel./Fax. 02-399 0939 E-mail : Sale1@siamhyd.com, website : www.siamhyd.com

# รูปชิ้นส่วนที่ผลิต (Job.M093)



Head Cylinder



Gland



Front Cover



Rod

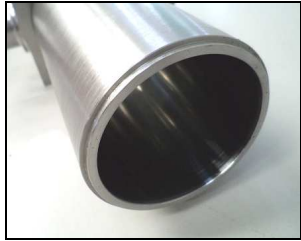

Tube Cylinder

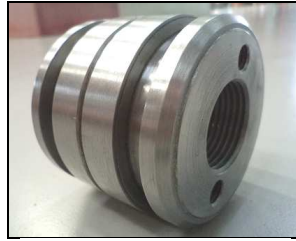

Piston



Cushion Sleeve

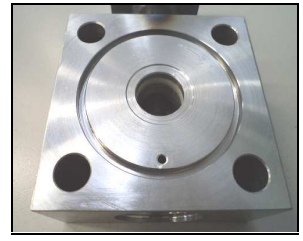

End Cylinder



Trunnion



Tie Rod Head



Tie Rod End



Pipe



Flange SSB15



Mounting Rod



Pin



Lock Nut



Nuts Set



Cushion Valve



Seal Kit

# ภาพการผลิต,ประกอบและทดสอบ Hydraulic Test (Job.M093)



## HYDRAULIC TEST REPORT

CUSTOMER NAME:

PROJECT NO.: SC-063/035.5-270-L010

TYPE: 63x35.5x270

REF. P/O NO. : -

DATE: -

QUOTATION NO. :-

DATE: -

QUALITY: 1 Set

DELIVERY DATE: -

## TEST PRESSURE

WORKING PRESSURE: 140 Bar

MAXIMUM TEST: 250 Bar

TESTING TIME: 30 Minute

TEST BY \_\_\_\_\_  
SERVICES TECHNICIAN

INSPECTION BY \_\_\_\_\_  
ENGINEER

SIAM HYD

**Siam Hydraulic Co.,Ltd**

High quality cylinders for heavy duty application