

HYDRAULIC CYLINDER “SC-063/035.5-220-N019”

Production Report For Mechanical Maintenance

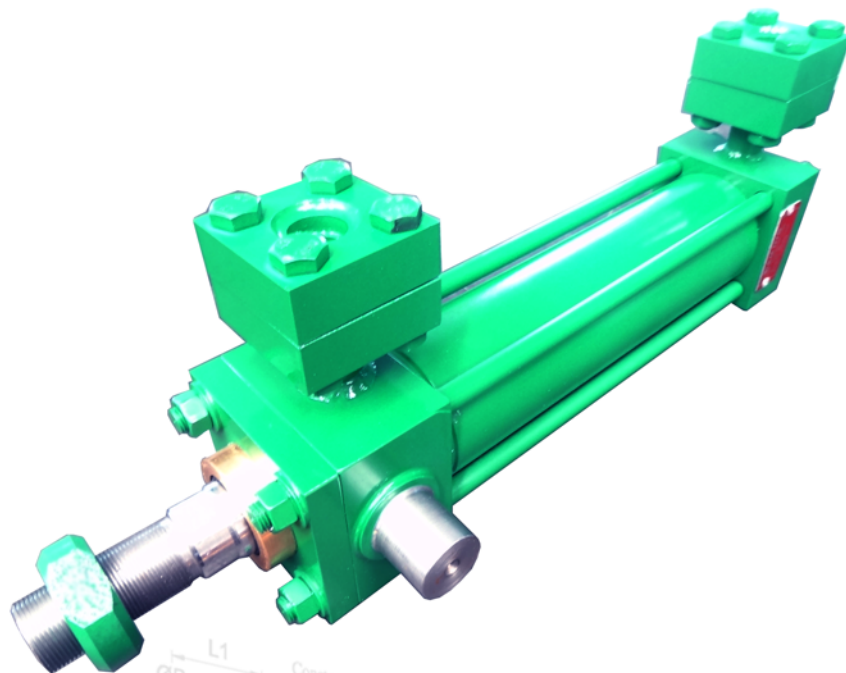

Job.N019

www.siamhyd.com

Hydraulic Cylinder “SC-063/035.5-220-N019”

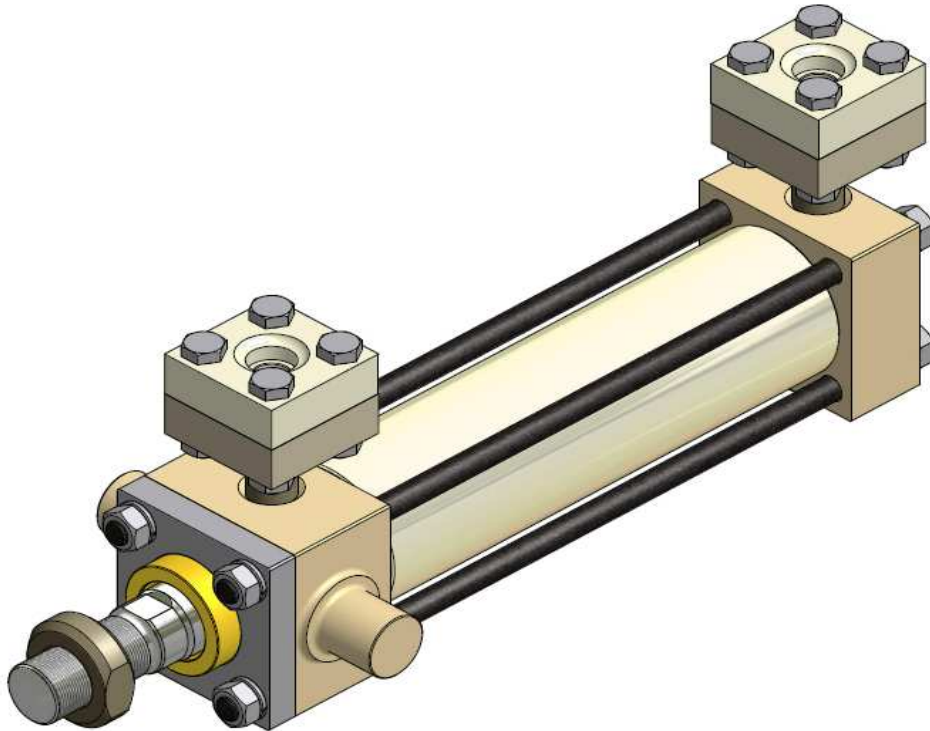

Hydraulic Cylinder 63x35.5x220

Bore size: **Ø63mm.**

Rod size: **Ø35.5 mm.**

Stroke: **220 mm.**

Working Pressure: **140 Bar**

SR No. : **61/020**

Job No. : **N019 (No.1,2)**



Siam Hydraulic Co.,Ltd.

888 Lasalle Road, Bangna Tai, Bangna, Bangkok 10260

SIAMHYD Tel./Fax. 02-399 0939 E-mail : Sale1@siamhyd.com, website : www.siamhyd.com

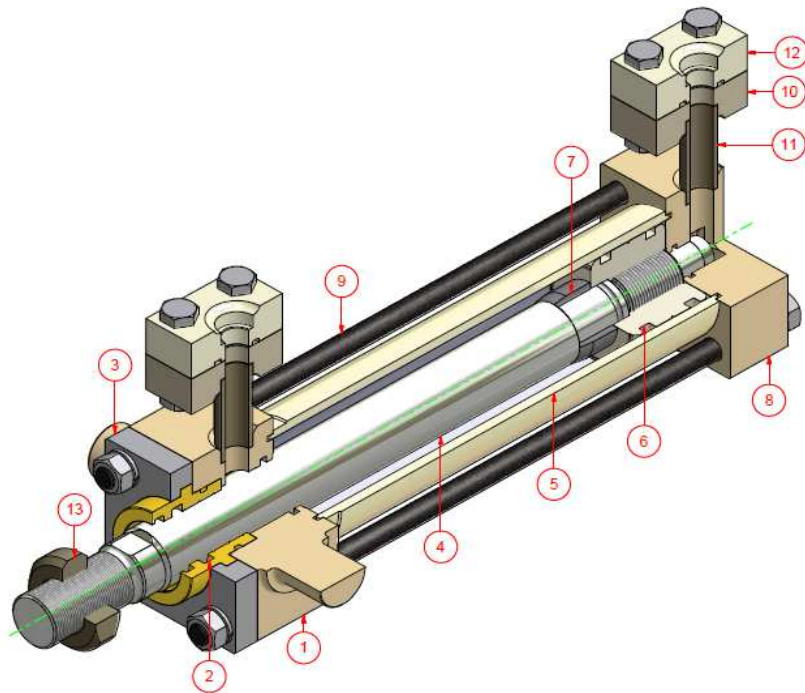

Part List SC-063/035.5-220-N019

ITEM	P/N	QTY	PART NAME
1	SP-N019-01-01	1	HEAD CYLINDER
2	SP-N019-01-02	1	GLAND
3	SP-N019-01-03	1	FRONT COVER
4	SP-N019-02-01	1	ROD
5	SP-N019-03-01	1	TUBE CYLINDER
6	SP-N019-04-01	1	PISTON
7	SP-N019-04-02	1	CUSHION SLEEVE
8	SP-N019-05-01	1	END CYLINDER
9	SP-N019-06-01	4	TIE ROD
10	SP-N019-06-02	2	FLANGE SHB 15
11	SP-N019-06-03	2	PIPE
12	SP-N019-06-04	2	FLANGE SHA 15
13	SP-N019-06-05	1	LOCK NUT

รูปชิ้นส่วนที่ผลิต (Job.N019)



Head Cylinder



Gland



Front Cover



Rod

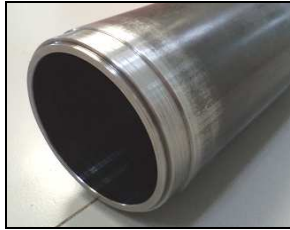

Tube Cylinder

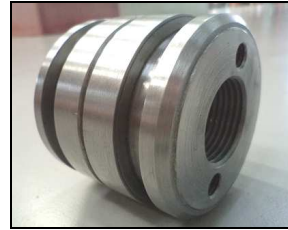

Piston



Cushion Sleeve



End Cylinder



Tie Rod



Flange SHB 15



Pipe

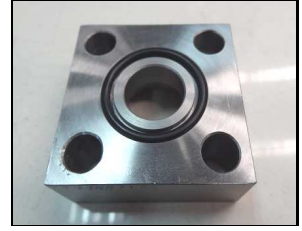

Flange SHA 15



Lock Nut



Nuts Set



Cushion Valve



Seal Kit

ภาพการผลิต,ประกอบและทดสอบ Hydraulic Test (Job.N019)



HYDRAULIC TEST REPORT

CUSTOMER NAME:

PROJECT NO.: SC-063/035.5-220-N019

TYPE: 63x35.5x220

REF. P/O NO. : -

DATE: -

QUOTATION NO. : -

DATE: -

QUALITY: 2 Set

DELIVERY DATE: -

TEST PRESSURE

WORKING PRESSURE: 140 Bar

MAXIMUM TEST: 250 Bar

TESTING TIME: 30 Minute

TEST BY

.....
SERVICES TECHNICIAN

INSPECTION BY

.....
ENGINEER



Siam Hydraulic Co.,Ltd.

888 Lasalle Road, Bangna Tai, Bangna, Bangkok 10260

Tel./Fax. 02-399 0939 E-mail : Sale1@siamhyd.com, website : www.siamhyd.com

SIAM HYD

Siam Hydraulic Co.,Ltd

High quality cylinders for heavy duty application