

HYDRAULIC CYLINDER FOR

“กระบอกลูกหัวเกี่ยวแบบทิสทางเดียว”

(SC-050/040-300-L051)

Production Report For Mechanical Maintenance



Job.L051



High Quality Cylinders

กระบอกยกหัวเกี่ยวแบบทิศทางเดียว “SC-050/040-300-L051”



Hydraulic Cylinder 50x40x300

Bore size: Ø50 mm.

Rod size: Ø40 mm.

Stroke: 300 mm.

Working Pressure: 100 Bar

SR No. : 59/069

Job No. : L051



Siam Hydraulic Co.,Ltd.

888 Lasalle Road, Bangna Tai, Bangna, Bangkok 10260

Tel./Fax. 02-399 0939 E-mail : Sale1@siamhyd.com, website : www.siamhyd.com



High Quality Cylinders

กระบอกยกหัวเกี่ยวแบบทิศทางเดียว “SC-050/040-300-L051”

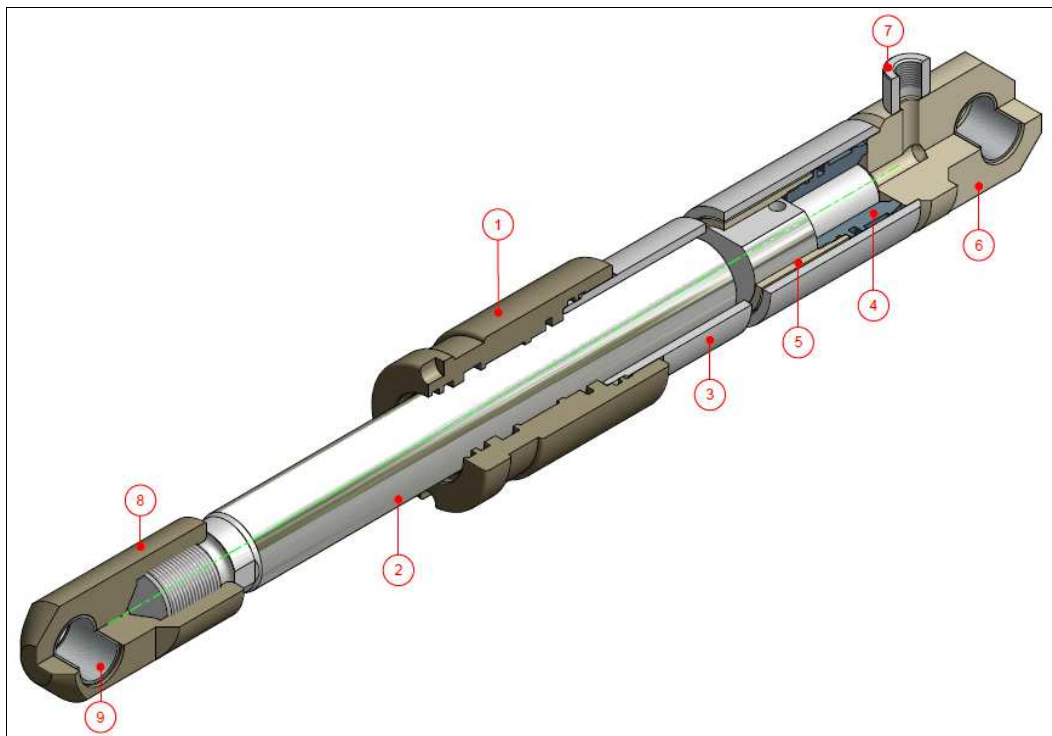

Part List

ITEM	PART NUMBER	PART NAME	MATERIAL	QTY
1	SP-E036-01-01	HEAD CYLINDER	S45C	1
2	SP-L051-02-01	ROD	CK45	1
3	SP-L051-03-01	TUBE CYLINDER	ST52-3	1
4	SP-L051-04-01	PISTON	S45C	1
5	SP-L051-04-02	STOP TUBE	ST52-3	1
6	SP-L050-05-01	END CYLINDER	S45C	1
7	SP-L051-06-01	END FITTING	S45C	1
8	SP-L051-06-02	MOUNTING ROD	S45C	1
9		DU BEARING	BZ/PTFE/STEEL	2



Seal Kit

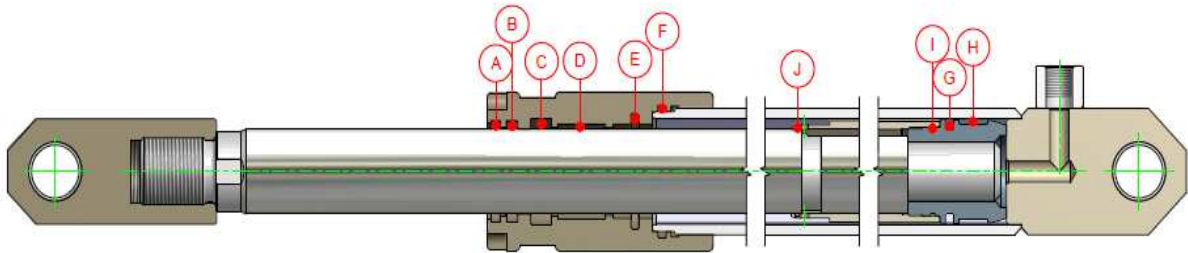

Seal Kit

ITEM	PART NUMBER	PART NAME	MATERIAL	QTY
A	PU5-040/7.8	WIPER	95AUV149	1 PC
B	T20-040	MUD SEAL	95AUV142	1 PC
C	T20-040E	ROD SEAL	95AUV142	1 PC
D	SB-040B	ROD GUIDE RING	HG517	1 PC
E	RS-044A	CUSHION SEAL	POM	1 PC
F	ORN-056-N9	O-RING	NBR	1 PC
G	8073-044A	PISTON SEAL	OMK-PU	1 SET
H	KB-050B	PISTON GUIDE RING	HG517	1 PC
I	ORN-037.82	O-RING	NBR	1 PC
J	ORN-040	O-RING	NBR	1 PC



High Quality Cylinders

Seal Kit



ITEM ; A



ITEM ; B



ITEM ; C



ITEM ; D



ITEM ; E



ITEM ; F



ITEM ; G



ITEM ; H



ITEM ; I



ITEM ; J



High Quality Cylinders

รูปชิ้นส่วนของ PART ที่สร้างใหม่ (Job.L051)



Head Cylinder



Rod



Tube Cylinder



Piston



Stop Tube



End Cylinder



End Fitting



Mounting Rod



DU Bearing



Seal Kit



High Quality Cylinders

ภาพงานผลิตชิ้นส่วน (Job.L051)





High Quality Cylinders

ภาพการประกอบกระบอกเซตร่วมศูนย์ และทดสอบ Hydraulic Test



HYDRAULIC TEST REPORT

CUSTOMER NAME:

PROJECT NO.: SC-050/040-300-L051

TYPE: 50x40x300

REF. P/O NO. : -

DATE: -

QUOTATION NO. :-

DATE: -

QUALITY: 2 Set

DELIVERY DATE: -

TEST PRESSURE

WORKING PRESSURE: 100 Bar

MAXIMUM TEST: 150 Bar

TESTING TIME: 30 Minute

TEST BY _____
SERVICES TECHNICIAN

INSPECTION BY _____
ENGINEER

7



Siam Hydraulic Co.,Ltd.

888 Lasalle Road, Bangna Tai, Bangna, Bangkok 10260

Tel./Fax. 02-399 0939 E-mail : Sale1@siamhyd.com, website : www.siamhyd.com

SIAM HYD

Siam Hydraulic Co.,Ltd

High quality cylinders for heavy duty application