

HYDRAULIC CYLINDER FOR

“กระบอกลูกท้อส่ง”

(SC-050/032-350-L050)

Production Report For Mechanical Maintenance



Job.L050



High Quality Cylinders

กระบอกยกท่อส่ง “SC-050/032-350-L050”



Hydraulic Cylinder 50x32x350

Bore size: Ø50 mm.

Rod size: Ø32 mm.

Stroke: 350 mm.

Working Pressure: 100 Bar

SR No. : 59/068

Job No. : L050



Siam Hydraulic Co.,Ltd.

888 Lasalle Road, Bangna Tai, Bangna, Bangkok 10260

Tel./Fax. 02-399 0939 E-mail : Sale1@siamhyd.com, website : www.siamhyd.com



High Quality Cylinders

กระบอกลูกทอส่ง “SC-050/032-350-L050”

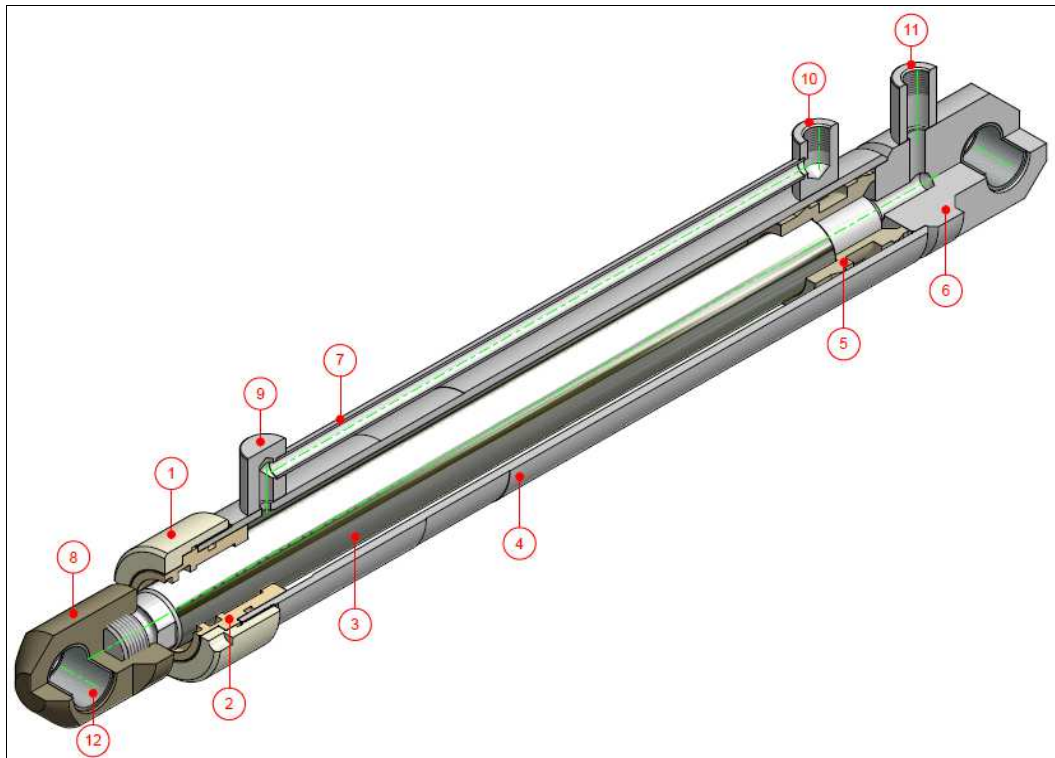

Part List

ITEM	PART NUMBER	PART NAME	MATERIAL	QTY
1	SP-E144-01-01	HEAD COVER	S45C	1
2	SP-E144-01-02	GLAND	S45C	1
3	SP-L050-02-01	ROD	CK45	1
4	SP-L050-03-01	TUBE CYLINDER	ST52-3	1
5	SP-L050-04-01	PISTON	S45C	1
6	SP-L050-05-01	END CYLINDER	S45C	1
7	SP-L050-06-01	PIPE	ST37	1
8	SP-L050-06-02	MOUNTING ROD	S45C	1
9	SP-E144-06-02	JOINT PIPE	S45C	1
10	SP-E144-06-04	FRONT FITTING	S45C	1
11	SP-E144-06-05	END FITTING	S45C	1
12		DU BEARING	BZ/PTFE/STEEL	2



Seal Kit

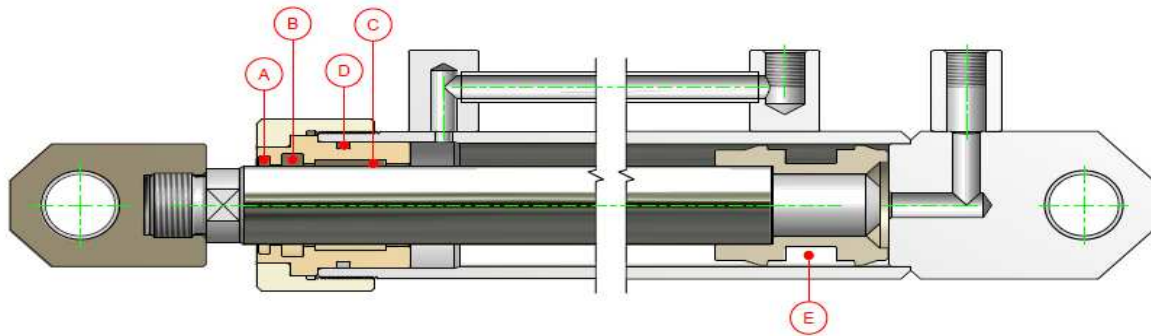

Seal Kit

ITEM	PART NUMBER	PART NAME	MATERIAL	QTY
A	PU5-032/7	WIPER	95AUV149	1 PC.
B	T20-032B	ROD SEAL	95AUV142	1 PC.
C	ORN-042.86x3.5V	O-RING	NBR	1 PC.
D	SB-032B	ROD GUIDE RING	HG517	1 PC.
E	L43-050	PISTON SEAL	78 NBR B281	1 SET.



High Quality Cylinders

Seal Kit



ITEM ; A



ITEM ; B



ITEM ; C



ITEM ; D



ITEM ; E



High Quality Cylinders

รูปชิ้นส่วนของ PART ที่สร้างใหม่ (Job.L050)



Head Cover



Gland



Rod



Tube Cylinder



Piston



End Cylinder



Pipe



Mounting Rod



Joint Pipe



Front Fitting



End Fitting



DU Bearing



Seal Kit



High Quality Cylinders

ภาพงานผลิตชิ้นส่วน (Job.L050)





High Quality Cylinders

ภาพการประกอบกระบอกเซตร่วมศูนย์ และทดสอบ Hydraulic Test



HYDRAULIC TEST REPORT

CUSTOMER NAME:

PROJECT NO.: SC-050/032-350-L050

TYPE: 50x32x350

REF. P/O NO. : -

DATE: -

QUOTATION NO. :-

DATE: -

QUALITY: 2 Set

DELIVERY DATE: -

TEST PRESSURE

WORKING PRESSURE: 100 Bar

MAXIMUM TEST: 150 Bar

TESTING TIME: 30 Minute

TEST BY

.....
SERVICES TECHNICIAN

INSPECTION BY

.....
ENGINEER

7



Siam Hydraulic Co.,Ltd.

888 Lasalle Road, Bangna Tai, Bangna, Bangkok 10260

Tel./Fax. 02-399 0939 E-mail : Sale1@siamhyd.com, website : www.siamhyd.com

SIAM HYD

Siam Hydraulic Co.,Ltd

High quality cylinders for heavy duty application