

HYDRAULIC CYLINDER FOR SC-030/018-060-J052

Production Report For Mechanical Maintenance

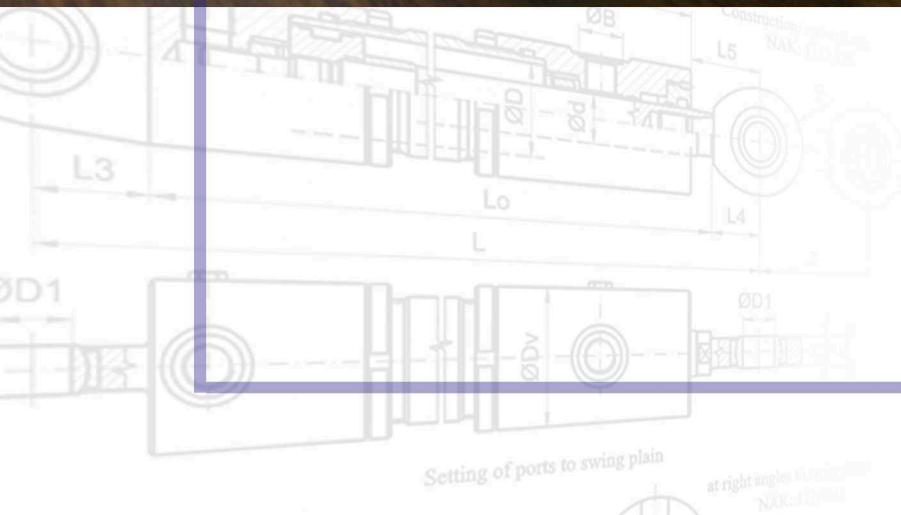

Job.J052

www.siamhyd.com



High Quality Cylinders

Hydraulic Cylinder



Hydraulic Cylinder 030x018x060

Bore size: Ø30 mm.

Rod size: Ø18 mm.

Stroke: 60 mm.

Working Pressure: 147 Bar

SR No. : 57/052

Job No. : J052



Siam Hydraulic Co.,Ltd.

888 Lasalle Road, Bangna Tai, Bangna, Bangkok 10260

Tel./Fax. 02-399 0939 E-mail : Sale1@siamhyd.com, website : www.siamhyd.com



SC-030/018-060-J052

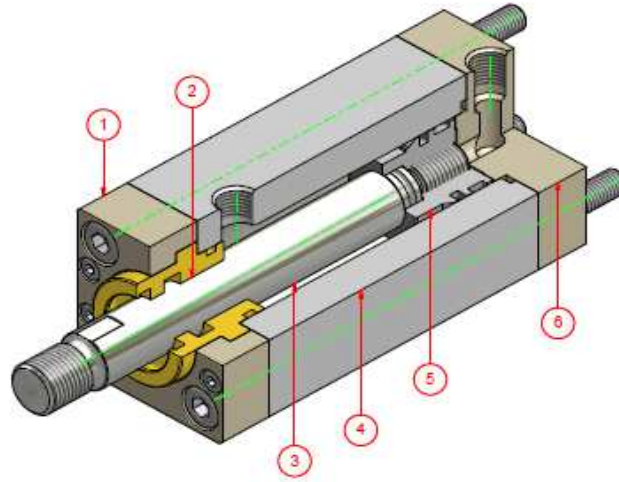

Part List SC-030/018-060-J052

ITEM	P/N	QTY	PART NAME
1	SP-J052-01-01	1	HEAD COVER
2	SP-J052-01-02	1	GLAND
3	SP-J052-02-01	1	ROD
4	SP-J052-03-01	1	TUBE CYLINDER
5	SP-J052-04-01	1	PISTON
6	SP-J052-05-01	1	END CYLINDER
7	ST030-018-J052	1 Set	SEAL KIT



High Quality Cylinders

รูปชิ้นส่วนของ PART ที่สร้างใหม่ (Job.J052)



Head Cover



Gland



Rod



Tube Cylinder



Piston



End Cylinder



Seal Kit



High Quality Cylinders

ภาพการผลิต,ประกอบและทดสอบ Hydraulic Test (Job.J052)

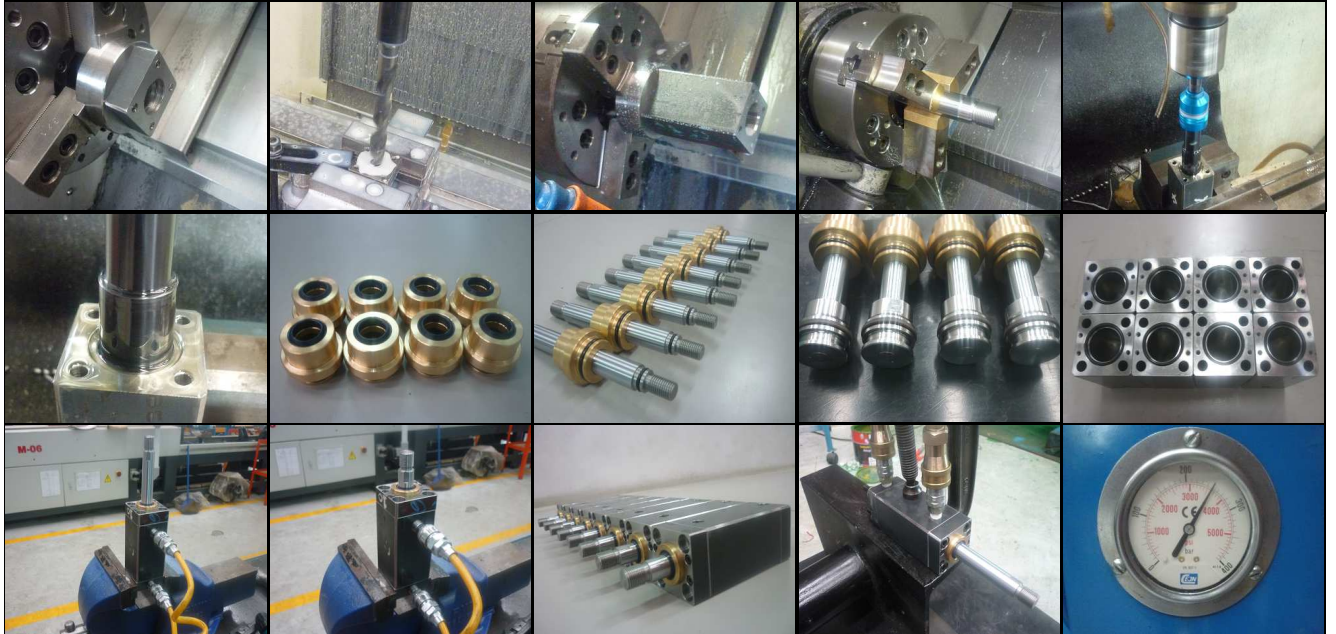

HYDRAULIC TEST REPORT

CUSTOMER NAME:

PROJECT NO.: SC-030/018-060-J052

TYPE: 30x18x60

REF. P/O NO. : -

DATE: -

QUOTATION NO. :-

DATE: -

QUALITY: 8 Set

DELIVERY DATE: 16/12/57

TEST PRESSURE

WORKING PRESSURE: 147 Bar

MAXIMUM TEST: 220 Bar

TESTING TIME: 30 Minute

TEST BY _____
SERVICES TECHNICIAN

INSPECTION BY _____
ENGINEER



Siam Hydraulic Co.,Ltd.

888 Lasalle Road, Bangna Tai, Bangna, Bangkok 10260

Tel./Fax. 02-399 0939 E-mail : Sale1@siamhyd.com, website : www.siamhyd.com

SIAM HYD

Siam Hydraulic Co.,Ltd

High quality cylinders for heavy duty application